

RYDEEN[®]



Owner's Manual

MiNy360

**MiNy 360° Dash Cam
with 3-inch Touch Screen**

Contents

| | |
|---|-----------|
| 1. Welcome Statement & Warnings | 2 |
| PRECAUTIONS & WARNINGS | 2 |
| 2. What’s in the Box | 3 |
| OPTIONAL ACCESSORIES | 4 |
| 3. Product Overview | 6 |
| Wiring Diagram | 7 |
| 4. Installation | 8 |
| 5. Windshield Installation Method | 8 |
| 6. Windshield Installation Method | 12 |
| 7. User Interfaces | 14 |
| Video Recording Icon | 15 |
| Photo Icon | 15 |
| File Lock Icon | 16 |
| Microphone Icon | 16 |
| Settings Icon | 16 |
| Video Settings | 16 |
| General Settings | 18 |
| Two Modes for Display | 18 |
| Replay Videos and View Photo Icon | 20 |
| IR Icon | 20 |
| Power Down | 20 |
| 8. APP Interfaces | 22 |
| Homepage | 22 |
| Playback Interface | 22 |
| Settings | 24 |
| Privacy Policy | 26 |
| 9. Video Player Installation (PC Only) | 34 |
| 10. Specifications | 38 |
| 11. Troubleshooting | 39 |
| 12. Technical Support Contact Info | 39 |
| 13. One Year Limited Warranty | 39 |
| 14. To Obtain Warranty Service | 40 |
| 15. FCC Compliance Statement | 41 |
| 16. Copyright | 41 |
| 17. Disclaimer | 42 |

1. Welcome Statement & Warnings

PRECAUTIONS & WARNINGS

IMPORTANT INFORMATION

PLEASE READ THIS MANUAL CAREFULLY BEFORE USING THE PRODUCT

1. Before installation, please check if the product list is complete and free of damage.
2. The installation instructions may differ from the actual installation process on a vehicle. If there are any discrepancies, please contact us.
3. Installation of the product is for Authorized Dealers only. Any installation not done through an Authorized dealer is not covered under warranty.
4. Please read this installation instruction manual carefully before installing the product.
5. Before turning on the product after installation, please confirm that the installation and wiring are correct.
6. Check whether the installed product functions properly. If there are any issues, please check if all connectors have been securely connected.
7. Check if the original vehicle functions are working properly. If there are any issues, please check if all wiring has been securely connected.
8. Please do not install the product if you receive a damaged item. Please take photos immediately and contact our Return Department. Photos should be provided that include all parts of the product and can display the damage.



- **DO NOT DROP ANY COMPONENTS OF THIS PRODUCT.** Excessive shock due to dropping any components in the system or subjecting it to excessive shock and vibrations may cause malfunction and is not covered by warranty.
 - **DO NOT use any sharp object to operate your unit's touch-screen display.** Excessive force could damage the LCD display.
 - **The MiNy360 Unit IS NOT WATERPROOF.** Avoid exposing it to rain or other forms of excessive moisture. **Only the rear camera is waterproof.**
 - **Water damage is not covered under the warranty.**
- THE FOLLOWING INSTRUCTIONS ARE RECOMMENDED FOR AUTHORIZED RYDEEN MOBILE INSTALLERS.**

2. What's in the Box

When opening the packaging box of this product, please make sure that all product accessories are complete.

Standard Package



MiNy360



Dashboard Bracket *1 (B)



Cigarette Lighter *1 (D)



Power Adapter Cable *1 (A)



AHD Rear Camera (CM-AHD7) *1 (C)



28ft AHD Camera Extension Cable *1 (C)



Wedge 1 (Angle:27°)

Wedge 2 (Angle:21°)

27° Wedge Bracket *1 & 21° Wedge Bracket *1 (B)



Electrostatic Sticker *1



32GB SD Card *1



Pry Tool *1

OPTIONAL ACCESSORIES



If you want to purchase the optional accessories, please contact your retailer or contact RYDEEN, Toll Free at 1-310-787-7880 for product support, or visit our website: <https://rydeenmobile.com/>

RYDEEN BRK01 (SOLD SEPARATELY)



Box Shape Camera Bracket



U-Shape Camera Bracket



Backup Camera Screws

RYDEEN DIGITAL AHD CAMERA (SOLD SEPARATELY)



CM-SIDE AHD



CM-V90 AHD



CM-AHD6

RYDEEN JB01 (SOLD SEPARATELY)



Jeep Wrangler Bracket

RYDEEN BL01 (SOLD SEPARATELY)



Universal License Plate Bracket

RYDEEN POWER WIRE HARNESS PWH-102 (SOLD SEPARATELY)



OPTIONAL ACCESSORIES USAGE SCENARIOS



3. Product Overview

MiNy360

FRONT

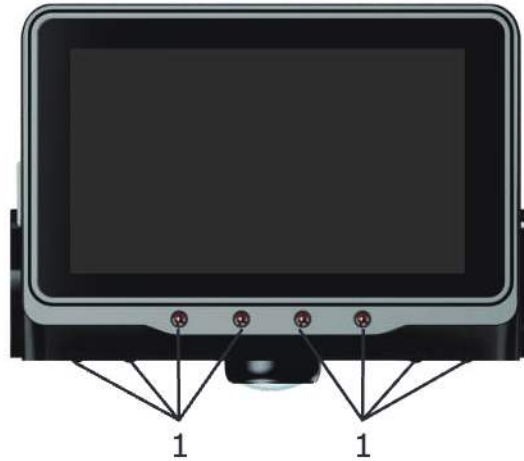

BACK



SIDE



| No. | Item | Description |
|-----|--------------------|---|
| 1 | IR Light * 8 | Equipped with eight infrared lights for night time visibility for the exterior & interior of vehicle. |
| 2 | 360° Camera | 360-degree surrounded view camera. |
| 3 | Speaker | You can adjust the volume in the settings menu, or turn off the speaker |
| 4 | Power Button | Long press to power ON/OFF the MiNy360. |
| 5 | MicroSD Card Slot | Insert or remove the microSD card. |
| 6 | 2.5mm Mini AV Port | Connect the AHD rear camera. |
| 7 | Reset Button | Press and hold within rest hole to restart the MiNy360. |
| 8 | Type-C Port | Connect the power wire harness. |

Wiring Diagram

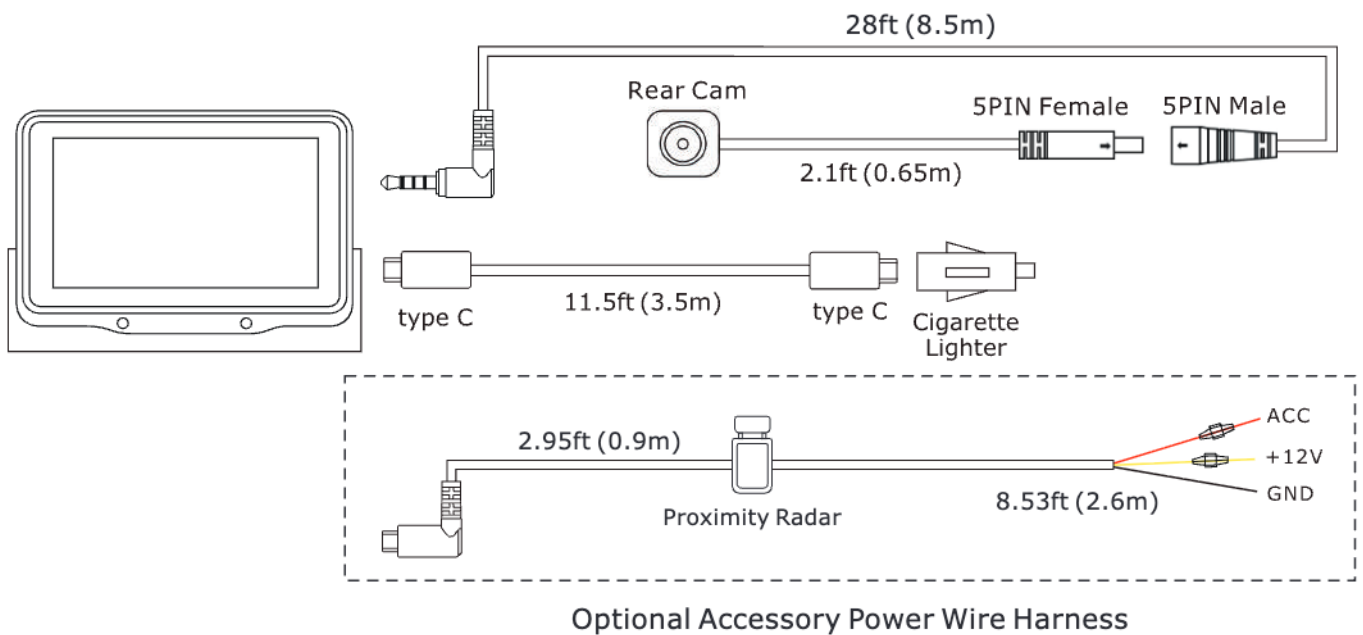

4. Installation



- **THE FOLLOWING INSTRUCTIONS ARE INTENDED TO GIVE YOU A BRIEF GUIDANCE FOR INSTALLATION.**
- **Dropping your MiNy360 unit or subjecting it to excessive shock and vibrations may cause it to malfunction and is not covered by warranty.**
- **Install the device carefully on the windshield. Improper installation or excessive force may cause damage to the glass. RYDEEN is not responsible for damage caused by improper installation.**

5. Windshield Installation Method

Step 1

Attach the Mounting Wedge to the MiNy360.

- 1) Select the appropriate mounting wedge (27° or 21°) based on the desired installation angle.
- 2) Align the wedge with the sliding slot on the back of the MiNy360.
- 3) Slide the wedge into the slot from right to left until it is fully seated.

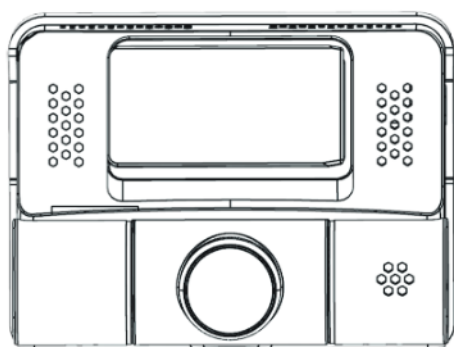

Wedge 1
(Angle:27°)

OR



Wedge 2
(Angle:21°)



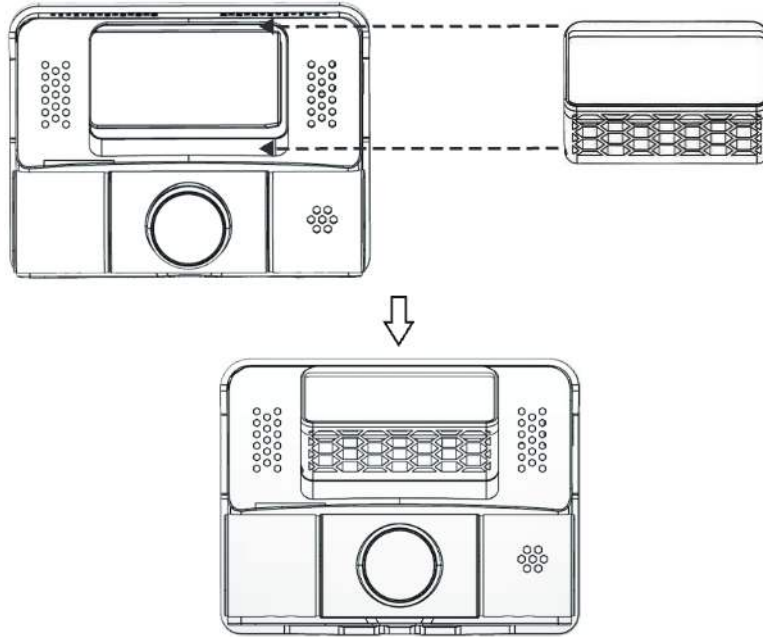

Step 2

Install the MiNy360 to the windshield.

- 1) Clean the selected windshield area thoroughly. Ensure the surface is dry, clean, and free of dust or oil before installation.
- 2) Select a mounting position on the windshield that does not obstruct the driver's forward view, preferably beside the original rearview mirror.
- 3) Apply the electrostatic sticker to the selected area. Attach one edge first, then press evenly to secure the sticker without air bubbles.
- 4) Mount the MiNy360 onto the electrostatic sticker and press firmly to secure.

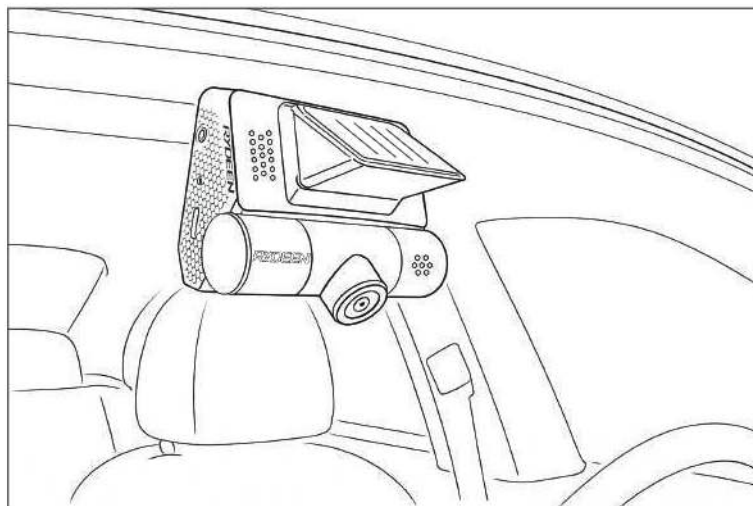

Step 3

Connect the cigarette lighter or power wire harness and use pry tool to route the wires according to the installation diagram (page 7).

For Cars

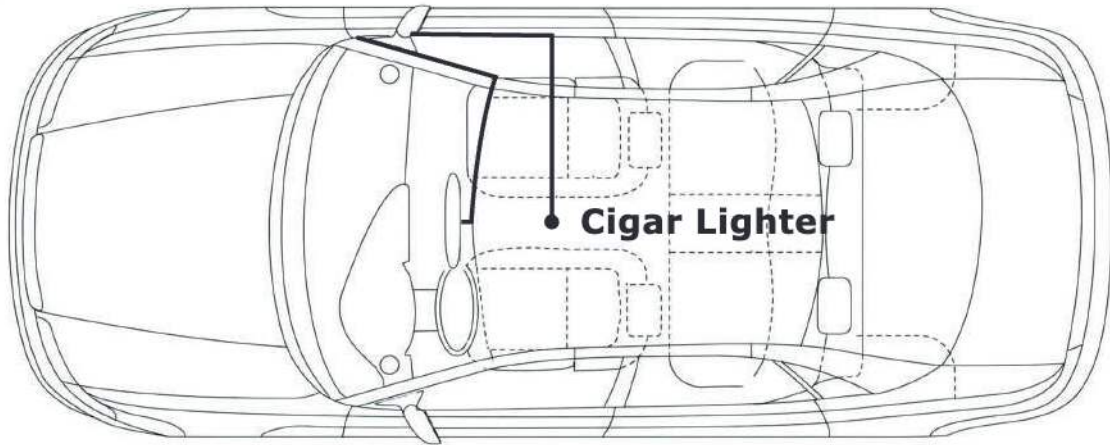

For Trucks

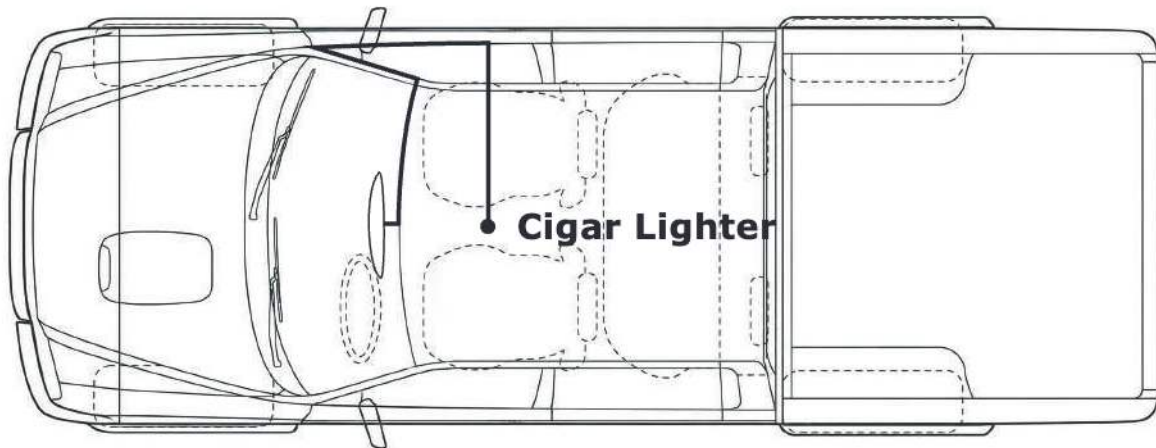

Inside View

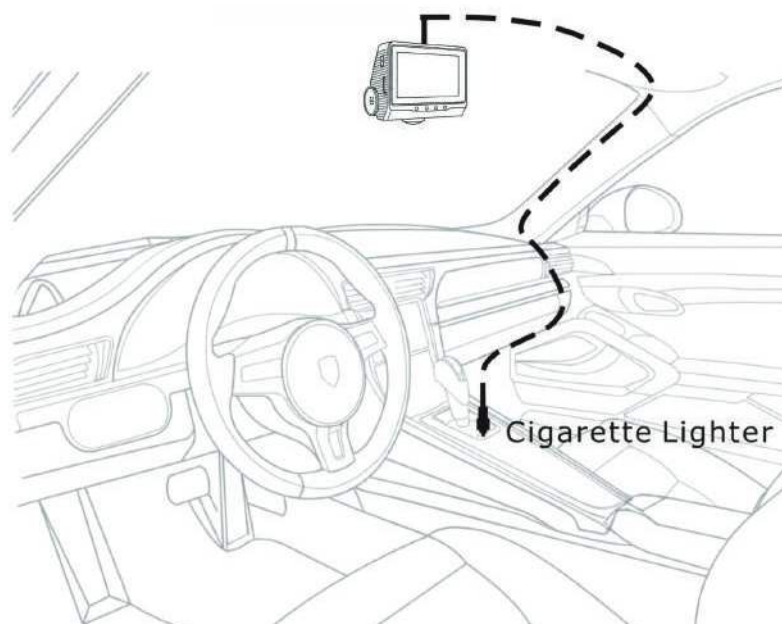

Backup Camera Installation Position Option Diagram

The camera (CM-AHD7) can be mounted using any of the following methods. Choose the configuration the best suits your vehicle. Use Wing Mount attached on camera (pre-installed). Rear windshield installation requires an optional BRK01 bracket.

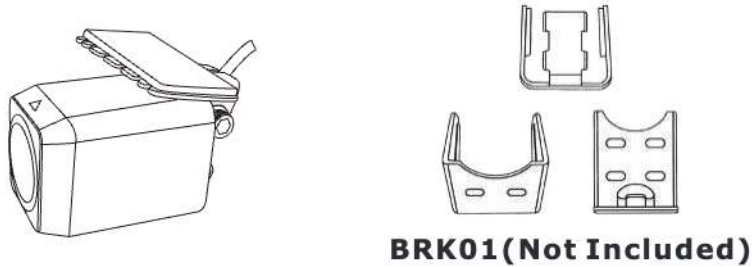

Rear windshield mounting location (interior top mounted) with optional BRK01 bracket (not included).

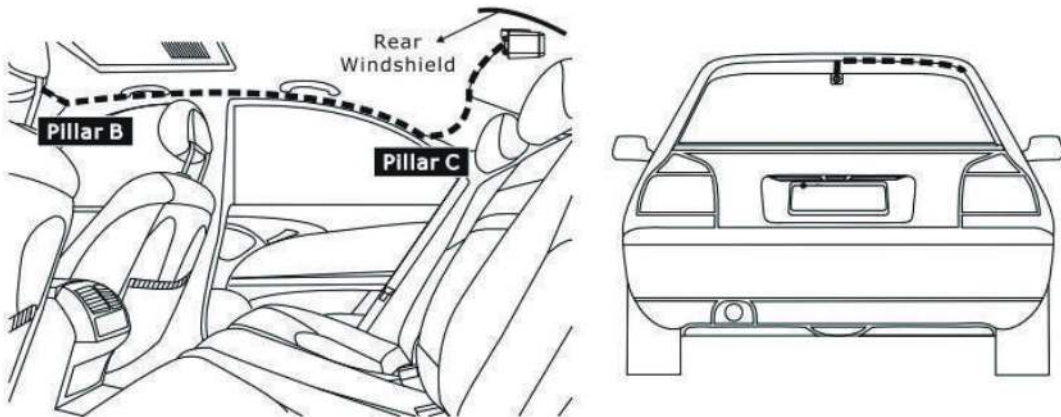

Above license plate mounting location (Exterior mounted)

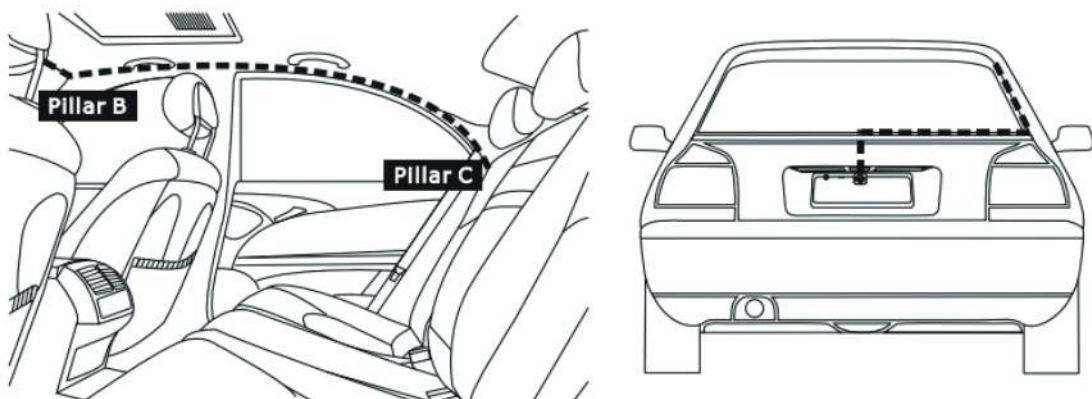

Step 4

Turn the vehicle on and verify that all the functions are working properly.

6. Dashboard Installation Method

(1) Attach the Dashboard Bracket to the MiNy360.

- 1) Align the dashboard bracket with the mounting interface on the MiNy360.
- 2) Attach the dashboard bracket to the MiNy360 until it is fully seated and securely engaged.

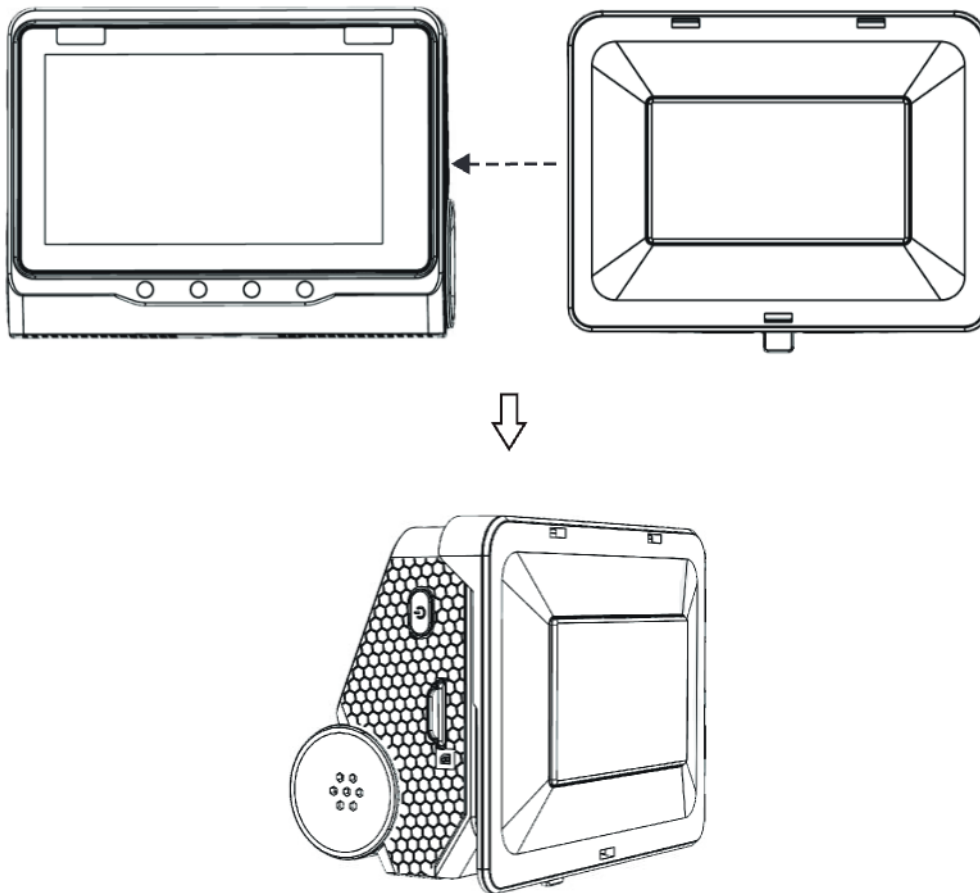

(2) Install the MiNy360 to the dashboard.

- 1) Select a flat and stable location on the dashboard, preferably near the center, ensuring the display is clearly visible and does not obstruct driving operation.
- 2) The gel adhesive pad is pre-installed. Remove the gel adhesive pad protective film and place the MiNy360 with the attached dashboard bracket onto the selected location.

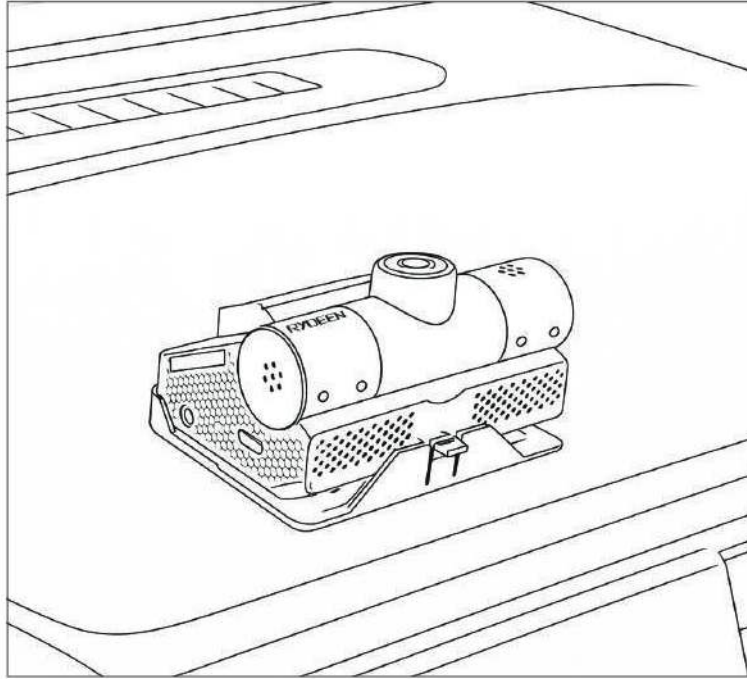

(3) Proceed to Step3 - Step4 on Page 9-Page 11.

7. User Interfaces

Start-up Screen

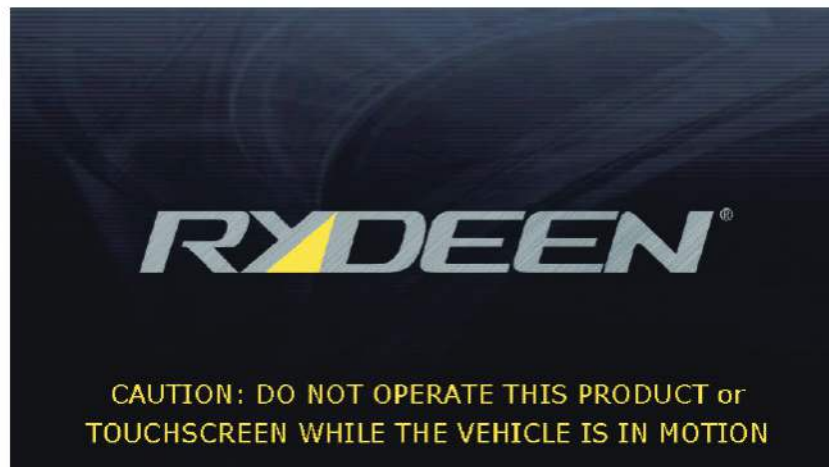

WARNING: Do not enter data or work the software's controls while operating a vehicle. It is dangerous to do so. Park vehicle prior to operating the device software. Manufacturer takes no responsibility for the consequence of any use that is inconsistent with this warning or the owner's manual contents.

Main UI



7.1 Video Recording Icon



The MiNy360 start recording automatically at startup (default). During the dash cam is in normal recording, the blinking red dot will appear in the top center. To stop / start recording, simply press on the icon.



NOTE: Maximum storage (microSD) size of MiNy360 is 256GB, minimum is 16GB. When a new microSD card is used, insert to the slot then go to the setting menu (7.5.2) to format. Bigger the size of memory card, the formatting will take longer time.

7.2 Photo Icon

Select the photo icon to take a snapshot. Images will be saved in “.jpeg” format inside the picture folder.

7.3 File Lock Icon

Press this icon to record SOS files. A small white lock icon will appear on the right side red dot recording indicator.



CAUTION: When recording a 30-second SOS video, to protect critical files, touchscreen user operations are disabled, except the snapshot photo shooting.

7.4 Microphone Icon

Tap to turn audio recording on/off. The icon appears red when audio recording is on, and white when off. Changing the mic state will end the current video and start a new recording.

7.5 Setting Icon

7.5.1 Video Settings

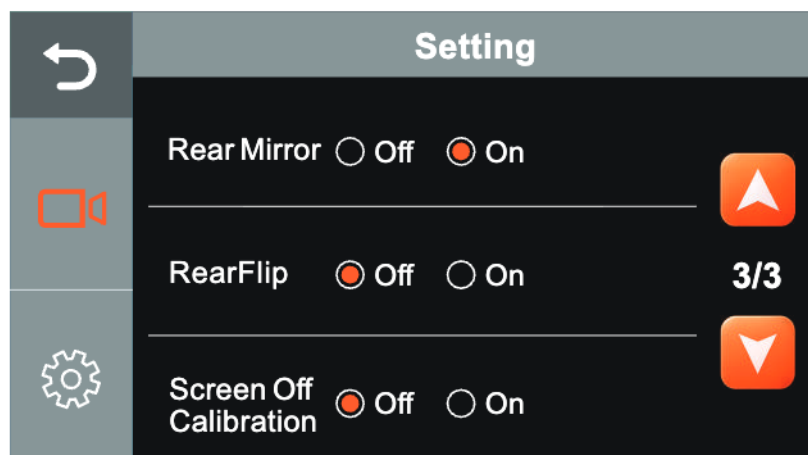
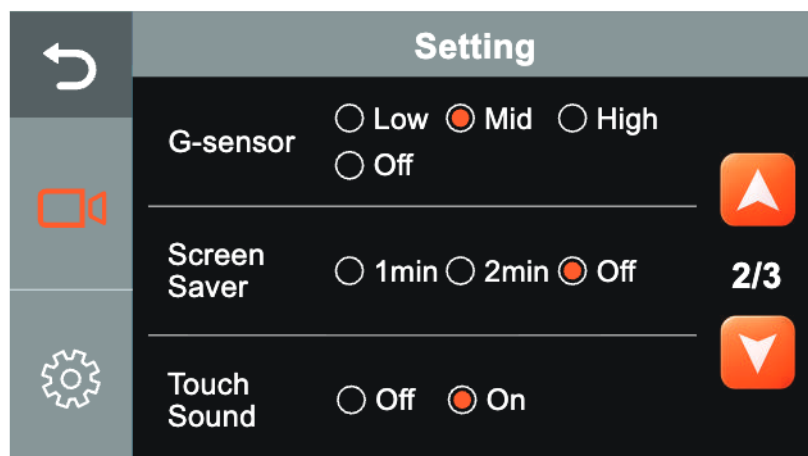
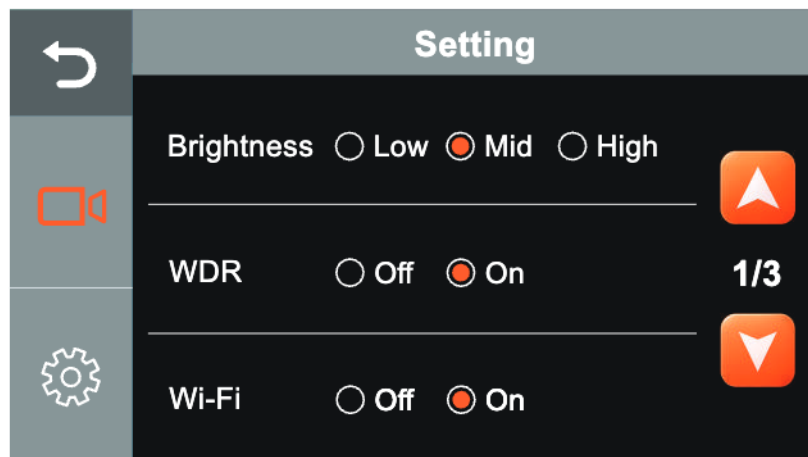

Brightness ----- Select the screen brightness level.

WDR ----- Turn on/off Wide Dynamic Range.

Wi-Fi ----- Turn on/off Wi-Fi connection with mobile phone APP.

G-Sensor ----- Select the sensitivity of the G-sensor. The higher the selection, the higher the sensitivity of the G-sensor. Selecting "Off" will disable the G-sensor during normal operation. In sleep mode, G-sensor will be enabled.

Screen Saver ----- Display will turn off automatically after selected time has been reached with no usage. Selecting "Off" will keep display on during vehicle operation.

Touch Sound ----- Turn on/off the system key touch sound.

Rear Mirror ----- Switch between standard view (Off) and mirror view (On) for rear image.

Rear Flip ----- Switch the rear display between standard view (Off) and flipped view (On).

Screen Off Calibration ----- When turned ON, place the dash cam with the screen facing down. The dash cam will memorize this orientation for about 10 seconds. After calibration, the screen will automatically turn off whenever the dash cam is placed at or near the memorized downward angle.

NOTE: Calibration ensures reliable auto screen-off. Repeat if mounting position changes.

7.5.2 General Settings

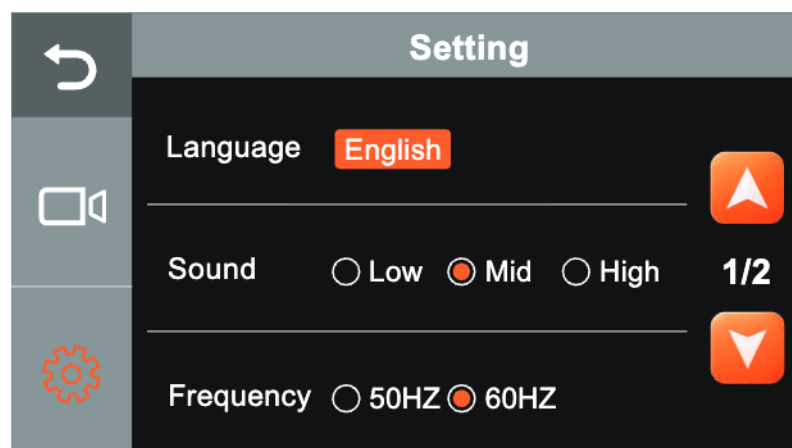

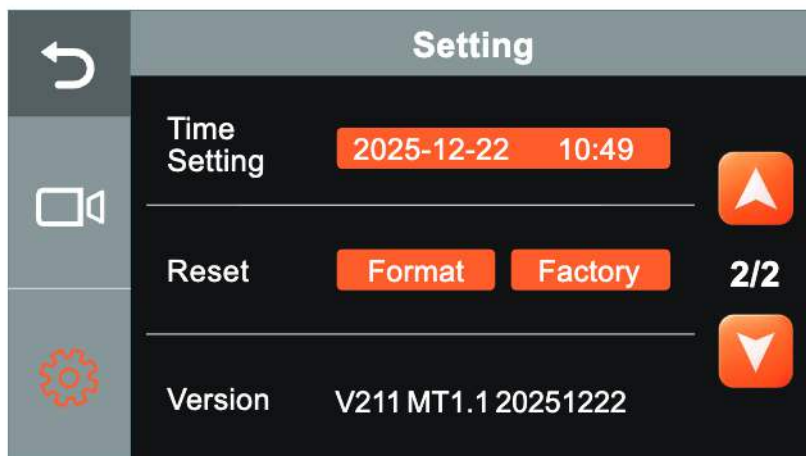

Language ----- Select the system language, there are four languages (English, French, Spanish, and Japanese)

Sound ----- Adjust volume level.

Frequency ----- Choose the frequency that matches your region's power standard to ensure stable, flicker-free video.

Time Setting ----- Manually set the date and time in the menu.

Format ----- Delete all files in microSD card.

Factory ----- Select this function to reset all settings back to default.

Version ----- Show current software version installed in your device.

7.6 Two Modes for Display

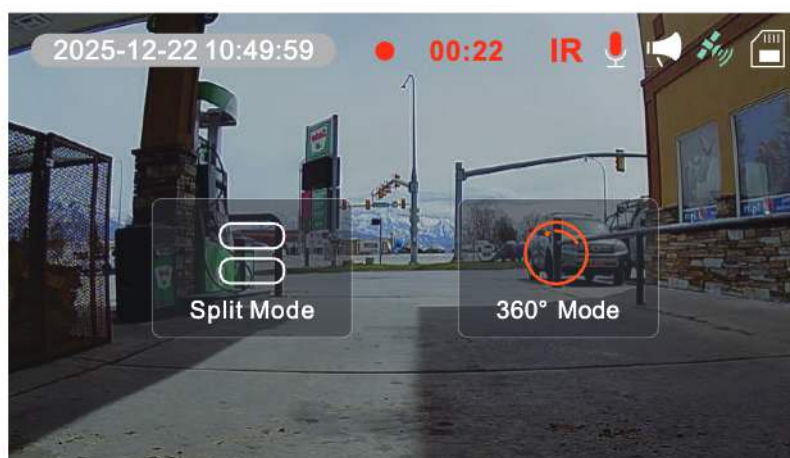

Split Mode

In split mode, you can orientate each individual screen to view a specific perspective of the front of the vehicle and inside view of the vehicle.



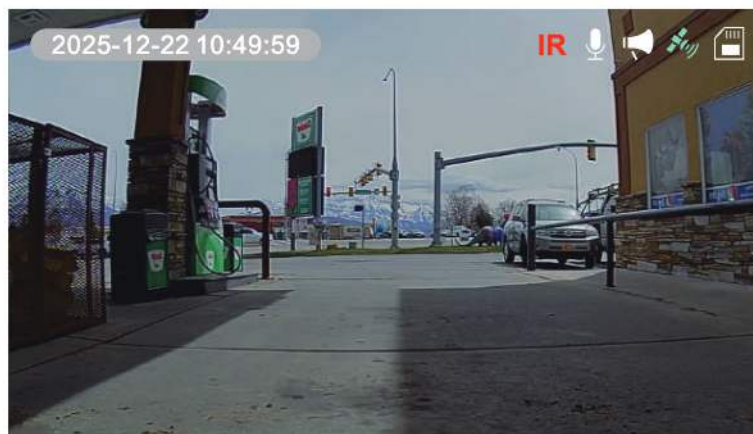

360° Mode

360° mode is the factory default display mode, which can be changed through the screen display mode selection icon. In this mode, you can swipe the screen left and right to view a 360-degree panoramic view of the inside and outside of the vehicle and view a particular perspective.

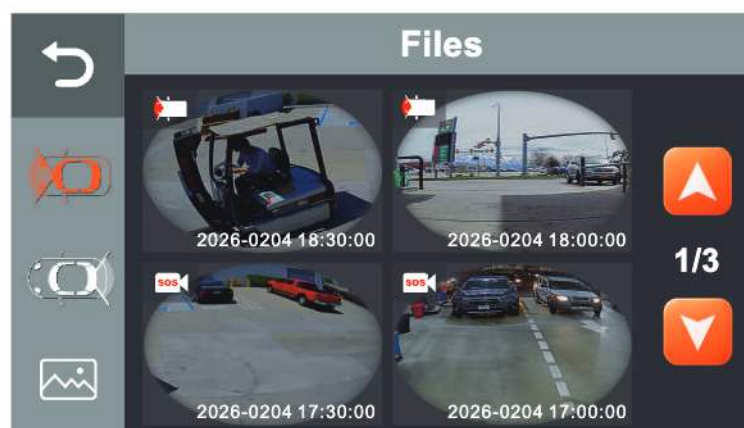

7.7 Replay Videos and View Photo Icon



Touch the icon  to enter the files for the front and backup camera recordings and view the snapshots. Recordings and images only viewable when system is not recording.

Select the icon  to view front camera recorded videos.

Select the icon  to view backup camera recorded videos.

Select the icon  to view the photos.

 indicates front camera files,  indicates rear camera files, and  indicates SOS recordings. SOS recordings are saved with an "SOS" tag.

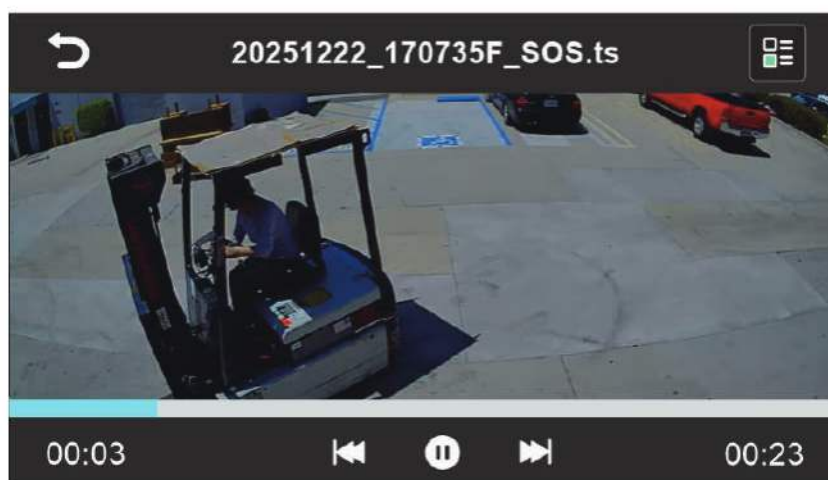

7.8 IR Icon

Tap to manually turn the 8 infrared LEDs on/off. The icon appears red when IR is on, and white when off. IR state must be set manually.

7.9 Power Down

After the vehicle ignition is turned off, a pop-up window will appear on the dashcam screen with three options: Power Off, Sleep, and Cancel.

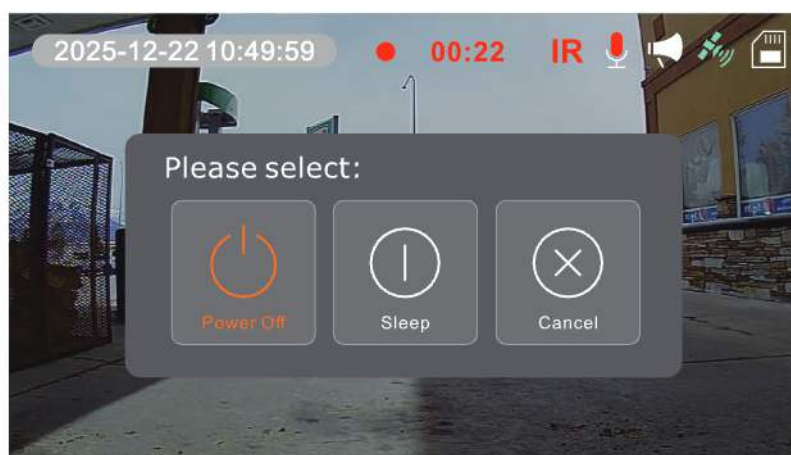

7.9.1 Power Off

If you choose Power off, the dashcam will turn off completely. In this mode, parking monitoring and the G-sensor are disabled and will not trigger any recording. However, the built-in proximity radar remains active. When the radar detects motion, it will wake up the dashcam, record a 60-second video, and then shut down again to conserve power.

NOTE: To protect your car battery, the radar automatically stops working when the battery voltage drops below 11.8V, ensuring the battery is not drained.

7.9.2 Sleep

Select "Sleep" to enter parking monitoring mode. In this mode, the internal 3-axis G-sensor is active: if a sudden or major collision is detected, the dashcam will record an SOS video as evidence. The proximity radar also works in sleep mode —when motion is detected, the dashcam records a 60-second normal video and then returns to sleep.

NOTE:

- 1) Sleep mode only works when the dashcam is powered via a hardwire kit with constant battery and ACC connections. If you are using a cigarette lighter, the Sleep function will not work. In that case, please do not select Sleep when using a car charger.
- 2) If you select sleep mode and then completely remove power (including from a USB Type-C car charger), the dashcam may repeatedly reboot when power is restored while an SD card is inserted. This is due to a temporary state flag saved in Sleep mode that conflicts with SD card initialization after a full power loss. To fix it, remove the SD card before re-powering, then reinsert and format it after the dashcam starts up. This does not happen with Power off or Cancel mode.

7.9.3 Cancel

If you select Cancel, the pop-up window is dismissed and the dashcam continues working normally, as if the ignition were still on.

8. APP Interfaces

To connect to mobile phone

Please download the Rydeen 360 from the following QR Codes.



iOS



Android

8.1 Homepage

The screenshot shows the Rydeen app interface with the following features highlighted:

- Wi-Fi Connection Status**: Green indicates connected; gray indicates not connected.
- Connected Device**: Show the name of the connected device.
- Device Switching**: Switch to another available device.
- Snapshot Capture**: Capture a still image.
- Recording Control**: Start or stop recording.
- Camera View Switching**: Toggle between front and rear camera views.
- Device Media Library**: Access videos stored on the device SD card.
- Home Interface**: Return to the video preview page.
- Video Management**: Access additional video management options.
- Image Mirror**: Enable or disable image mirroring.
- Flip Image**: Flips the video image vertically to correct orientation.
- Full-Screen Mode**: Enter full-screen display mode.
- Mic Icon**: Tap to turn audio recording on/off.
- Local Media Library**: View media stored on the mobile device.
- User Account Center**: Access account settings and user information.

8.1.1 Device Switching Interface



Note: After selecting any device, the system will display three connection guide images.

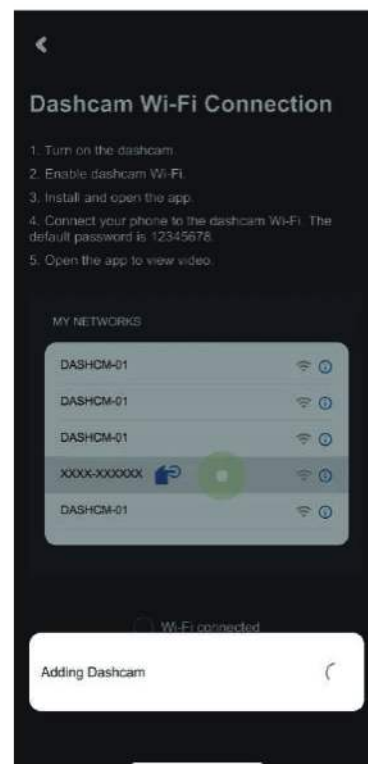
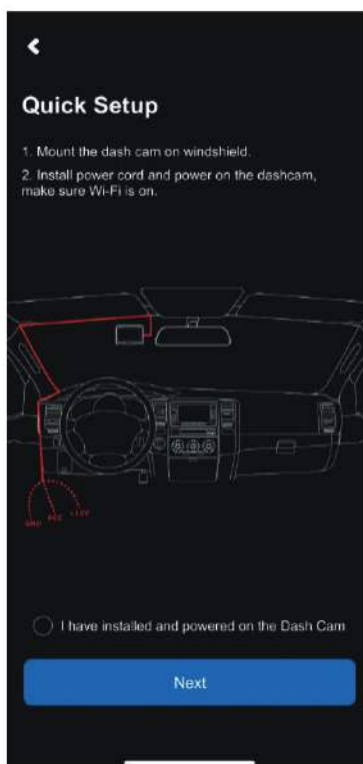

8.2 Playback Interface

- 1 **Fisheye View**
Original fisheye image
- 2 **Split Views**
Two views displayed
- 3 **Quad Views**
Four views displayed
- 4 **Panoramic View**
Wide panoramic view
- 5 **Single View**
Single standard view

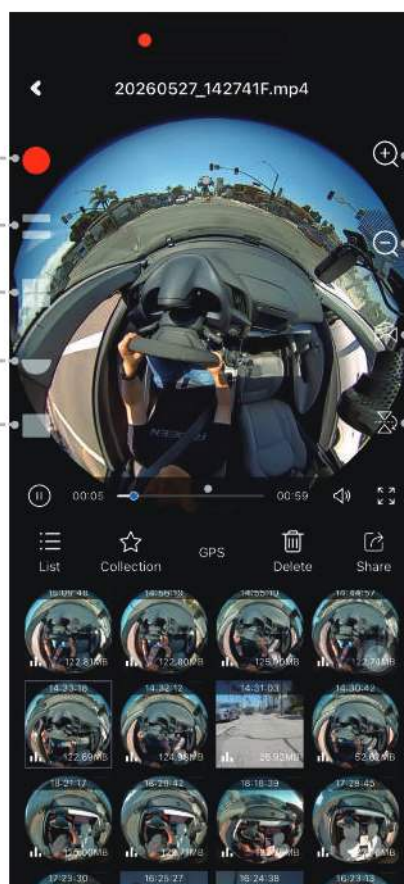

- 6 **Zoom In**
Enlarge the video view
- 7 **Zoom Out**
Reduce the video view
- 8 **Horizontal Mirror**
Flip the image horizontally
- 9 **Vertical Mirror**
Flip the image vertically

8.3 Settings

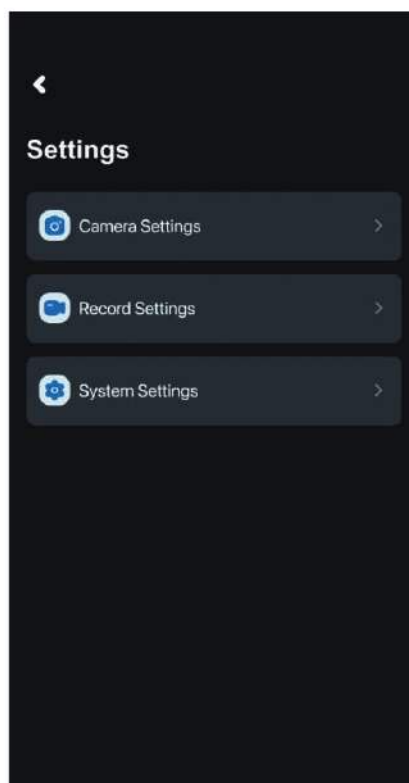

8.3.1 Camera Settings

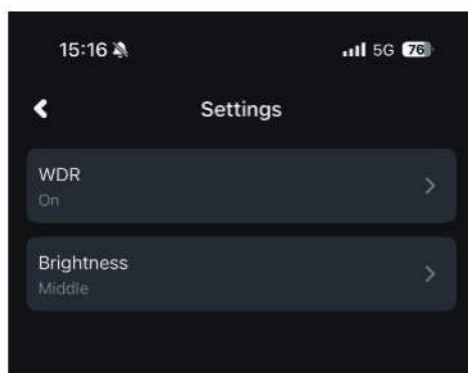

WDR ----- Turn on/off the Wide Dynamic Range function for front camera

Brightness ----- Adjusts the brightness level of the display to suit ambient light

8.3.2 Record Settings

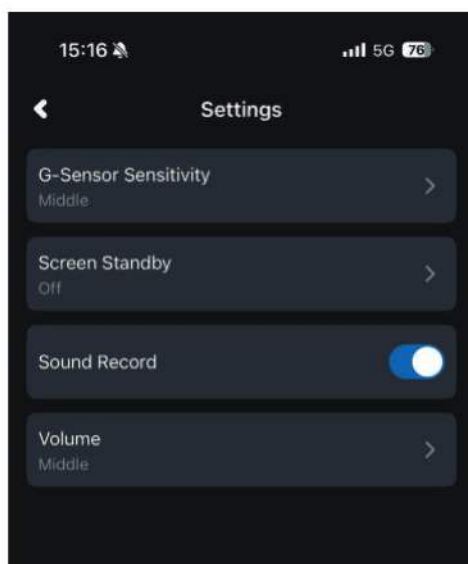

G-Sensor Sensitivity ----- Adjust the G-sensor sensitivity for the device(Off / High / Medium/ Low)

Screen standby ----- Set the idle time before the screensaver activates (Off / 1 min / 2 min / 3 min)

Sound Record ----- Turn audio recording on or off (ON / OFF)

Volume ----- Adjust the system volume level of operation sounds

8.3.3 System Settings



image 1



image 2

Wi-Fi Name ----- The broadcast name of the dash cam's Wi-Fi. Can be changed to your preference.

Wi-Fi password----- The key required to connect to the camera's Wi-Fi. Can be customized. Default Wi-Fi Password: 12345678.

Language ----- Select the dash cam system language (Japanese / French / English / Spanish).

Light Frequency ----- Set to match your local power frequency to prevent light flickering in recordings. Select 50Hz or 60Hz as applicable.

Format microSD Card ----- Select this option to delete all files stored on the microSD card.

Factory Reset ----- Select this option to restore all settings to factory default.

OTA Update ----- Wirelessly upgrade your dash cam's firmware through the app. Ensures your dash cam has the latest features, performance improvements, and bug fixes.

Firmware Version ----- Device Firmware version information.

Note:

- 1) When the mobile app is connected via WiFi, the DVR function can only be controlled through the app. Touchscreen will be turned off during APP connection, it will be turned on and operated after exiting the app for 30 seconds.
- 2) For safety, park in a secure location and engage the parking brake before connecting the mirror app via WiFi, as the rearview monitor and camera functions will be disabled.
- 3) Keep your vehicle's ACC on while using the app to download videos or watch live camera footage on your phone.
- 4) After changing the Wi-Fi name and password, you need to press and hold the power button to restart the device for the new name and password to take effect.

8.4 Privacy Policy

"Rydeen 360" Internet service is provided by Rydeen Mobile Electronics . We regard users' privacy as everyone's basic right. At any time, when you contact us or use "Rydeen 360" related services, we may ask you to provide personal information. We collect, use, store, protect and provide such information in strict accordance with this privacy policy, so as to improve our products, services, content and advertising. You have the right to refuse to provide the personal information we require when necessary; This privacy policy is closely related to the "Rydeen 360" service you use. We strive to express it in easy to understand, concise and concise words, and remind you to pay attention to the important provisions related to your rights and interests in this Privacy Policy in bold. We

hope you can read it carefully and make appropriate choices.

1. What personal information may we collect

1.1 Personal information refers to all kinds of information recorded electronically or in other ways that can identify the identity of a specific natural person or reflect the activities of a specific natural person alone or in combination with other information; When you use the services we provide, we may collect, use and store all kinds of information. In many cases, if you choose not to provide the personal information required below, "Rydeen 360" may not be able to provide you with some or all of the products or services, or achieve the intended effect of the relevant services; At the same time, we may not be able to respond to your problems.

1.2 Personal information that may be collected within the meaning of this privacy policy includes:

1.2.1 Information you provide: including but not limited to your nickname, avatar, gender and mobile phone number; Among them, the mobile phone number belongs to personal sensitive information.

1.2.2 when you use the Rydeen 360 community function or change your personal avatar to take pictures, we will turn on your camera permission with your authorization. The above permissions are sensitive. We only enable them when you need to use the corresponding functions.

1.2.3 We will collect your equipment information and WiFi MAC of dash cam through technical means.

1.2.4 Your information shared by third parties: shared information about you provided by third parties when using our services.

1.2.5 Based on different business scenarios, the Rydeen 360 Intelligent APP has been connected to third-party SDKs. The Rydeen 360 Intelligent APP will only use your personal information for legitimate, legitimate, and necessary purposes, and will take strict security measures to protect your personal information. The required personal information and privacy policies are listed one by one. Click to read more information

1.2.6 Our app provides logoff function, which takes effect in real time without manual audit. After logging off, all the user's data will not be retrieved. Please use the log off function carefully.

1.2.7 To allocate servers nearby and improve the overall use and access speed of users, we will collect your IP addresses.

1.2.8 In order to achieve the service purpose of "PaFiling", the personal information collected by "PaFiling" through technical means is limited to your mobile phone ID, mobile phone MAC, SIM serial number, Android_ID, IMSI, device serial number, basic information of the DASH CAM (we use mobile phone ID, MAC address, SIM serial number, Android_ID, IMSI, device serial number, and recorder ID to distinguish between application software exceptions for problem analysis and feedback) and use time.

1.2.9 Description of MAC sensitive information: We obtain the MAC address of the mobile phone to uniquely distinguish the mobile phone information, so as to collect the APP problem log, better analyze and modify the problem for the specific mobile phone environment, so as to bring better experience to users;

1.2.10 In order to monitor the Rydeen 360 error exceptions and optimize and upgrade the platform, we will collect the application software operation exception information.

1.2.11 We will collect your device information (MAC address), browsing and operation records in order to realize operation fault reporting and analyze and solve the problems you encounter in the process

1.2.12 In order to prevent fraud and protect your information security during use, we will collect your device location information.

1.2.13 Getting the list of installed apps: We get the list of installed apps to enable users to list all the apps that offer sharing functions when they choose to share videos and photos, so as to achieve a better sharing experience.

2. How might we use your personal information

For your personal information collected in the process of providing services to you, we may use it for the following purposes:

2.1 The services we provide to you are divided into basic functions, additional service functions and services provided by third parties. We will explain in detail the personal information collected and used by each service function, the collection method and purpose, and the possible impact of refusing to provide personal information. Service functions include:

2.1.1 Basic functions, including Internet of vehicles interconnection applications.

2.2 Before using the services we provide, you need to create an account in "Rydeen 360" and improve your personal data to ensure the applicability and security of the services we provide you. We will collect your following information in the way you offer:

2.2.1 You need to provide your mobile phone number and register on the "Rydeen 360" page to identify your network membership in "Rydeen 360" and provide you with our services. If you refuse to provide your mobile phone number, we will not be able to create an account and provide services for you.

2.2.2 When you use "Rydeen 360" to connect the recorder function, we will collect the WiFi MAC of your recorder and complete the recorder authorization function service.

2.2.3 You need to provide us with but not limited to nickname, avatar, gender and other information in order to enjoy more services and rights of "Rydeen 360".

2.3 Services that you can use through the "Rydeen 360" service and are supported by a third party. During your use of such services, we will collect (including the information you provide and the information recorded in the system) and necessary personal information, and share them with the third party providing service support with your consent, And indirectly obtain relevant information about your use of the service from a third party. If you refuse us to collect and share such information, you will not be able to use the corresponding third-party services.

2.4 The privacy protection policy of the third party will apply to the personal information you provide directly to the third party when using the third party service through "Rydeen 360", or the personal information you authorize us to share with the third party. When you view web pages created by third parties or use applications developed by third parties, these third parties may place their own cookies or pixel tags. These cookies or pixel tags are not under our control, and their use is not subject to this policy. We will make commercially reasonable efforts to require these subjects to take protective measures for your personal information, but we cannot guarantee that these subjects will take protective measures according to our requirements. Please read their privacy protection policy carefully before use to determine whether to continue to use the third-party service.

2.5 Please understand that the services provided by "Rydeen 360" to you are constantly updated and developed. If a service is not included in the above description and your information is collected, we will separately explain the content, scope and purpose of information collection to you through page tips and other means for your consent.

3. User rights and responsibilities

3.1 Only individuals and organizations that meet one of the following conditions can apply to become Rydeen 360 platform users and use the services under this Agreement:

3.1.1 A natural person who has reached the age of 18 and has the capacity for civil

rights and civil conduct;

3.1.2 Natural persons under the age of 18 but with the written consent of their guardians (including but not limited to their parents);

3.1.3 Enterprises, legal persons, institutions, mass organizations and other organizations established and legally existing in accordance with Chinese laws and regulations. If a person without civil capacity, a person with limited civil capacity or an organization without business or specific business qualification is improperly registered as a user, the agreement between them and the company shall be invalid from the beginning. Once the company finds out, it has the right to cancel the user immediately.

3.2 Users have the right to use various network services provided by Rydeen 360 platform to members in accordance with the procedures and requirements specified by Rydeen 360 platform. If members have objections to the service, they can contact Rydeen 360 platform for timely resolution.

3.3 When applying for the network service of Rydeen 360 platform, users must provide accurate personal data to Rydeen 360 platform. In case of any change in personal data, they must be updated in time.

3.4 Users must agree to accept the Rydeen 360 platform to send relevant business information to members by e-mail or other means.

3.5 When using Rydeen 360 platform services, users must abide by the provisions of relevant laws and regulations of the people's Republic of China, and shall not use this service for any illegal or improper activities, including but not limited to the following acts:

3.5.1 Make, copy, publish, disseminate or otherwise transmit information containing one of the following:

- Opposing the basic principles set forth in the constitution
- Endangering national security, divulging state secrets, subverting state power and undermining national unity;
- Harming the honor and interests of the state;
- Inciting national hatred, national discrimination and undermining national unity;
- Undermining state religious policies and propagating cults and feudal Superstitions;
- Spreading rumors, disturbing social order and undermining social stability;
- Spreading obscenity, pornography, gambling, violence, murder, terror or abetting crime;
- Insulting or slandering others and infringing upon the lawful rights of others;
- Inciting illegal assembly, association, procession, demonstration or gathering people

to disturb social order;

- Activities in the name of illegal civil society organizations;
- Contains false, harmful, threatening, infringing on others' privacy, harassment, infringement, slander, vulgar, obscene, or other morally objectionable content;
- Containing other contents restricted or prohibited by Chinese laws, regulations, rules, regulations and any legally effective norms.

3.5.2 Do not use Rydeen 360 services for the following activities:

- Entering the computer information network or using the computer information network resources without permission;
- Deleting, modifying or adding computer information network functions without permission;
- Deleting, modifying or adding data and application programs stored, processed or transmitted in the computer information network without permission;
- Deliberately making and spreading destructive programs such as computer viruses;
- Other acts endangering the security of computer information network.

3.6 You agree to indemnify and hold harmless Rydeen 360 platform, partners and affiliates from any claims, demands or losses claimed by any third party, including reasonable attorney fees, caused or incurred by the user's violation of the provisions of this agreement or relevant terms of service. In this regard, Rydeen 360 platform has the right, depending on the nature of the user's behavior, to take measures including but not limited to deleting the information content published by the user, suspending the use license, terminating the service, restricting the use, recovering the account number of Rydeen 360 platform, and investigating legal liabilities. For malicious registration of Rydeen 360 platform account or illegal activities, disturbance, harassment, deception, other users and other violations of this agreement by using Rydeen 360 platform account, Rydeen 360 platform has the right to recover its account. At the same time, the company will assist in the investigation as required by the judicial department.

3.7 The user shall not copy, copy, sell, resell or use any part of the Rydeen 360 platform for any other commercial purpose in any way.

3.8 Users must bear legal responsibility for their actions in the process of using Rydeen 360 platform services. The forms of legal liability borne by the user include but are not limited to: compensation for the infringed, and after the Rydeen 360 platform operation company first bears the administrative punishment or tort damage liability caused by the user's behavior, the user shall give the Rydeen 360 platform operation company an equal amount of compensation.

4. intellectual property right

4.1 Rydeen 360 platform website and any relevant software, programs and contents used by the website, including but not limited to works, pictures, files, materials, website structure, website layout arrangement, web design, advertisements or information presented to users through this website or advertisers, shall be legally entitled to corresponding intellectual property rights by the company or other obligees, including but not limited to copyright Trademark rights, patent rights or other exclusive rights are protected by relevant laws. Without the express authorization of the company or the obligee, the user guarantees not to modify, rent, lend, sell, distribute the website and any of the above materials and resources used by the website, or make any kind of articles based on the above materials and resources.

4.2 The company grants the user a non transferable and non exclusive right to use the object code of the website (hereinafter referred to as "software") through a stand-alone computer, but the user shall not and shall not allow any third party to copy, modify, create derivative works, carry out original restoration works, reverse translation, or decode or attempt to decode the source code in other ways, or sell Transfer or sublicense the software, or otherwise transfer any rights in the software. The user agrees not to modify the software in any way or use the modified software.

4.3 Rydeen 360 platform has the right to mark "this function is provided by Rydeen 360 platform" and other relevant copyright information on all function interfaces provided by the platform.

4.4 Users are not allowed to use this website through the interface not provided by Rydeen 360 platform.

5. other

5.1 If the performance of this agreement is impossible, unnecessary or meaningless due to force majeure or other accidents, neither party shall be liable. Force majeure as mentioned in this agreement refers to unforeseeable, unavoidable and insurmountable objective conditions, including but not limited to war, typhoon, flood, fire, lightning or earthquake, strike, riot, legal disease, hacker attack, network virus, technical control of telecommunications department, government action or any other natural or man-made disaster.

5.2 The validity and performance of this clause and its amendments and all matters related to the effectiveness of this clause and its amendments will be governed by the laws of the people's Republic of China, and any dispute shall only be governed by the laws of the people's Republic of China.

5.3 Any dispute or dispute between the user and the company arising from this clause shall be settled through friendly negotiation. If the negotiation fails, the user hereby agrees to submit the dispute or dispute to the people's court with jurisdiction in the place where the company is domiciled for litigation.

5.4 After the user correctly submits the data required for the registration procedure and confirms this agreement, this agreement is established and takes effect between Rydeen 360 platform and the user.

5.5 Registered users before this agreement takes effect only need to log in to the Rydeen 360 platform website with the original user name and password, accept and confirm this agreement again, and then they can continue to use the services of Rydeen 360 platform.

5.6 Validity of the agreement: from the time when the user agrees to this agreement or uses the Rydeen 360 platform to the time when the user logs off the Rydeen 360 platform service.

5.7 If there are no special provisions in this agreement, both parties shall contact the relevant matters of this agreement by e-mail.

5.8 The e-mail addresses of relevant departments of Rydeen 360 platform shall be subject to those indicated on the official website of Rydeen 360 platform.

5.9 Using the Rydeen 360 platform means accepting the Rydeen 360 platform service agreement and all its attachments.

5.10 The final interpretation right of this agreement belongs to Rydeen 360 platform.

9. Video Player Installation (PC Only)

MiNy360 uses Pre-allocating file management to provide you with a safer experience. If you need to play the video on your PC, please check the provided microSD card in the device.

There is a file named "Tombo360Setup" inside of folder "exe", please install and run the software on your PC.

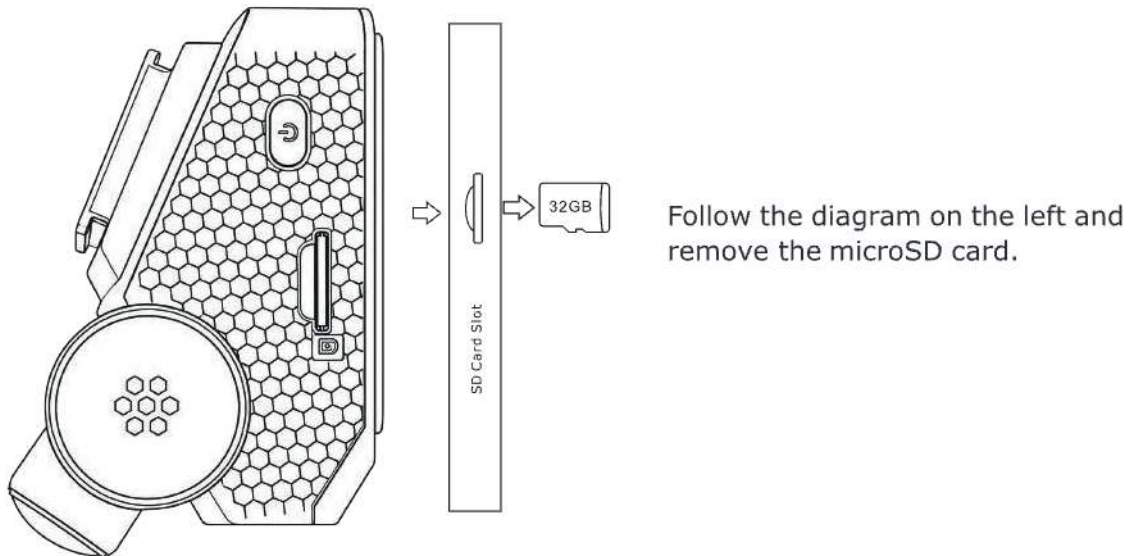

Note: MiNy360 uses Pre-allocating memory for file management. The system will generate 0-byte files in the folder during initialization. When recording videos are generated, the recording videos will occupy the 0-byte files one by one. Please use the provided video player in the microSD card to playback the recorded videos, if you want to view the videos on a PC.

Pre-allocating File Management Instructions

As shown in the example right, the blue squares represent the recorded video files and the black squares represent the pre-allocated storage space. Assuming that the microSD card has only 7 pre-allocated storage spaces and the duration of video "3" and video "8" is half a minute and the other videos are 1 minute.

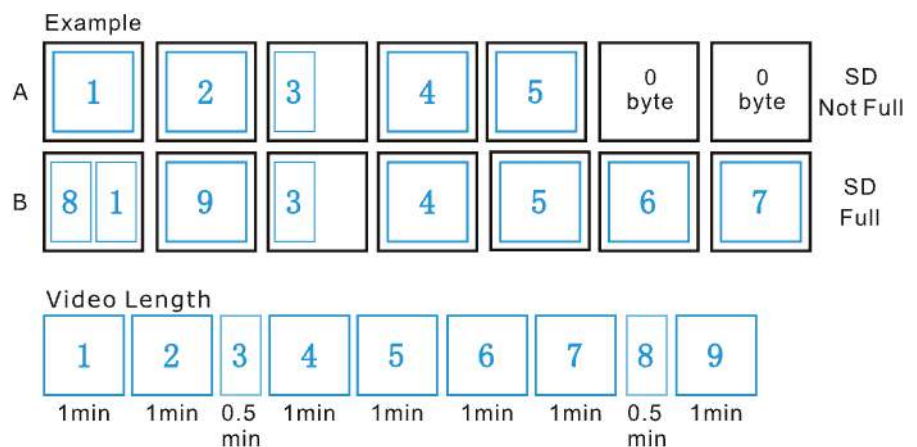

Case A, when the microSD card is not full, video "1", video "2", video "3", video "4", video "5" will be stored in the pre-allocated storage spaces in sequence. The remaining pre-allocated storage space will show 0-byte files.

Case B, when the microSD card is full. Since the storage device only has 7 the pre-allocated storage spaces, video "8" will occupy a portion of video "1" and video "9" will completely overwrite video "2".

MiNy360 Video Player Instructions

RYD360_Viewer Menu



- 1) Version Check: Click on the software version number to update to the latest version available. Over the Air update support only available with online access.
- 2) Play Mode: Play mode switch. In selection gives three choices (Sequence, Random, Repeat).
- 3) Add: Add videos to list.
- 4) Del: Delete a single video.
- 5) Clear: Clear video file list.
- 6) Right mouse click to select speed unit display (MPH, KM/H).
- 7) Prev: Play previous video.
- 8) Pause/Play: Pause/play video.
- 9) Nex: Play next video.
- 10) Stop: Stop video playback.
- 11) Down: Playback video recording angle in downward facing view.
- 12) Top: Playback video recording angle in top facing view.
- 13) Front: Playback video recording angle in front facing view.

- 14) Split2: Display playback video in dual screen mode (front/back).
- 15) Split4: Display playback video in quad screen mode (front/back/left/right).
- 16) 360Surround: Playback video recording in 360 surround view.
- 17) Wide: Display playback video in wide angle.
- 18) Volume: Adjust the volume of the video.
- 19) Open: Open the folder to select video to play.
- 20) Convert: Convert recorded video files into MP4 format.
- 21) FullScreen: Full screen display.
- 22) Help: Instructions of the RYD360_Viewer.
- 23) Minimize: Hide the RYD360_Viewer display.
- 24) Maximize/Restore: Maximize/restore the RYD360_Viewer display.
- 25) Close: Close the RYD360_Viewer.

RYD360_Viewer Rear Camera Menu

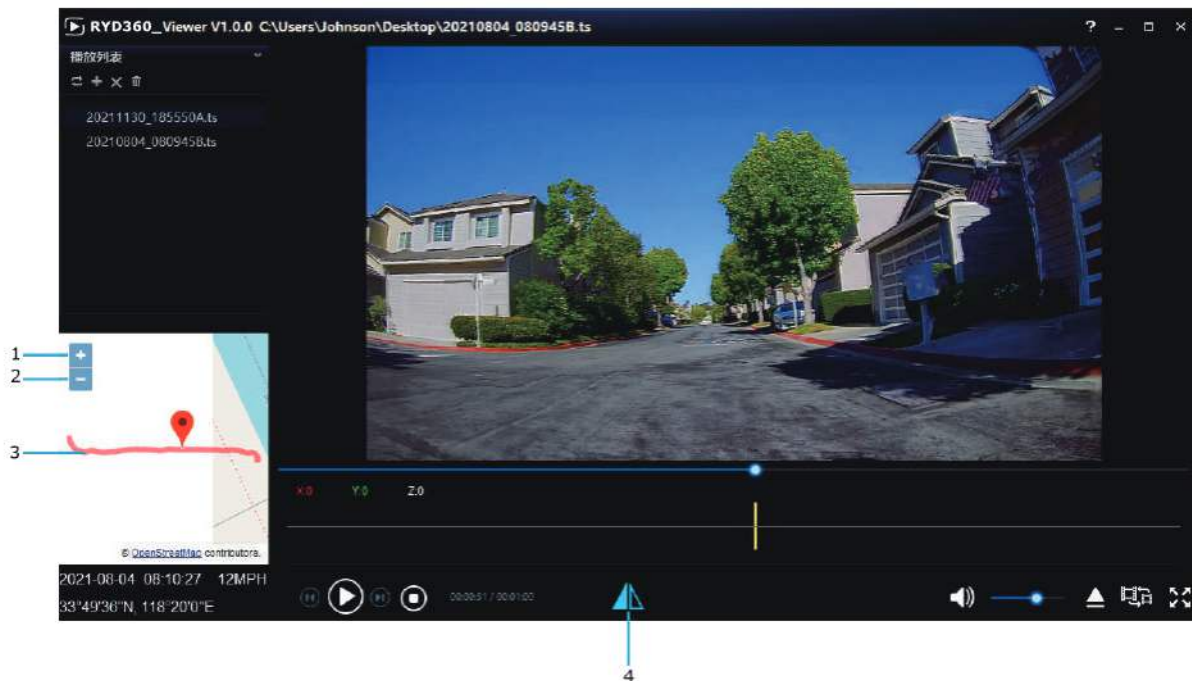

- 1) Zoom in: Zoom in the map.
- 2) Zoom out: Zoom out the map.
- 3) GPS trace playback.
- 4) Mirror On/Off: Display mirror/original image.

Conversion

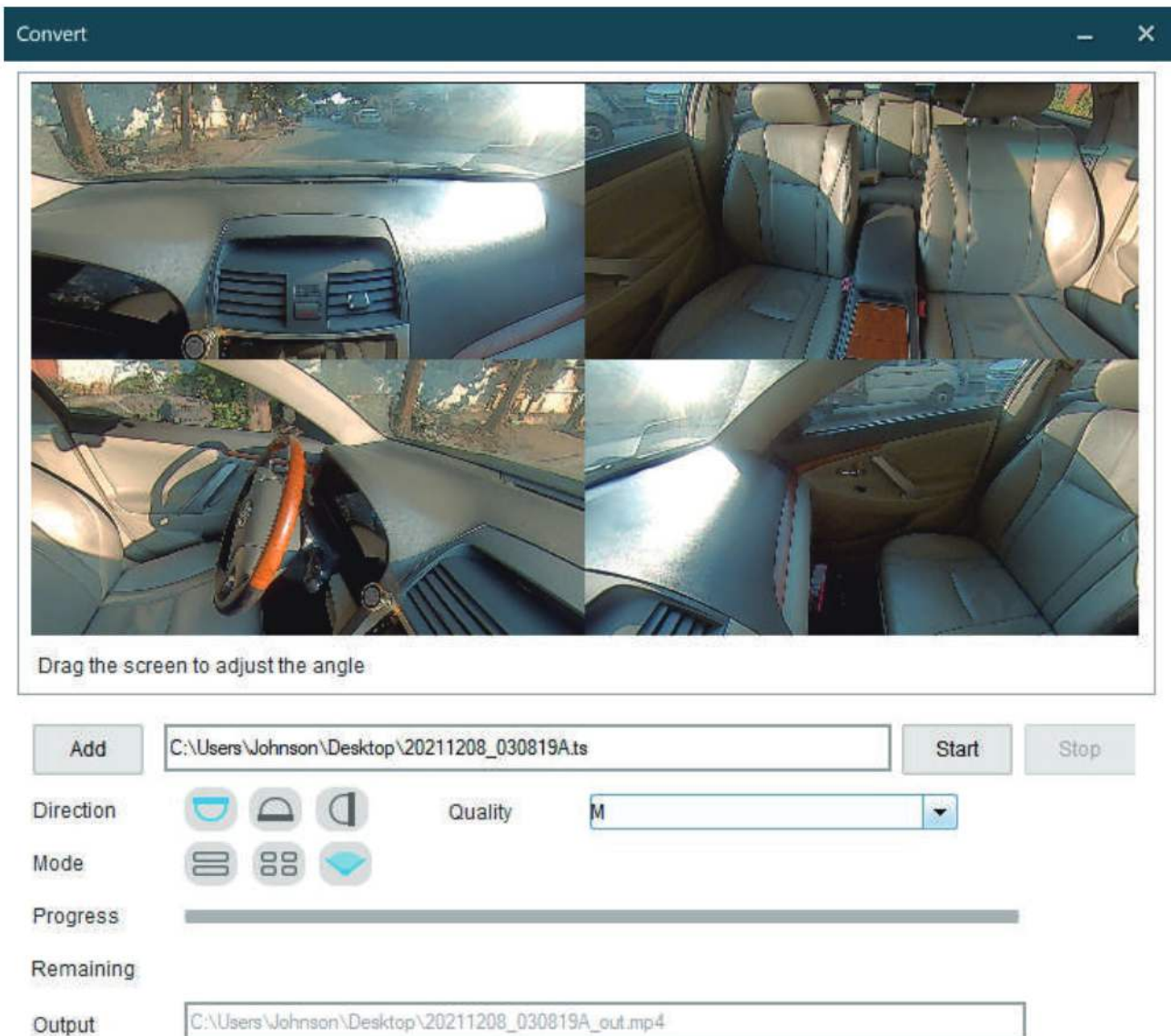

Add: Select the video file to be converted.

Direction: Select the front camera recorded direction.

Quality: Select the resolution of the video.

Mode: Select the video displayed mode. Only useful with front 360° camera.

Progress: Display the progress of the conversion.

Remaining: Displays the remaining time required for the video conversion to complete.

Output: Displays the saved location of the converted video.

Note:

1. The RYD360_Viewer player is only compatible on Windows Operating Systems.
2. The RYD360_Viewer player is compatible on Windows7 and newer.
3. When you use the conversion function, do not use the file storage path with Spaces, this will cause the video conversion to not work properly.

10. Specifications

| Basic Parameters | |
|-----------------------------|---|
| Video Input (backup camera) | AHD |
| System Language | English, French, Spanish, Japanese |
| Screen Dimensions | 480 × 854 |
| Front Camera | 1920×1920 / H: 360° / V: 220° |
| Wi-Fi | 5.8G |
| Speaker | 8Ω / 1W |
| GPS | Built-in |
| Power Supply Voltage | DC 5V (DC 12V~24V) |
| Rated Current | Built-in microSD card (Class10 high-speed card) |
| Super Capacitor | 5.5V@5F |
| System | Linux |
| Storage | MicroSD / ≥class10 / 16GB-256GB |
| Operational Temperature | -20°C~ +70°C |
| Storage Temperature | -30°C~ +80°C |
| Operational Humidity | 45%~80%RH |
| Storage Humidity | 30%~90%RH |
| Backup Camera Parameters | |
| Resolution | 1920*1080 |
| Construction | 2G+3P |
| Water Proof | IP67 |
| Viewing Angle | H: 106°±5° / V: 58°±5° |

11. Troubleshooting

- No display: Check to ensure the cable is properly connected and terminal connection is not loose.
- Rydeen logo stuck on screen start-up: Please insert a small pin into reset hole and restart.
- GPS suddenly no signal:
You have entered a tunnel or other area where there is no GPS signal.
- GPS Time Zones shows wrong time: This may be that the time zone of your area cannot be accurately identified by GPS. Please manually select the correct time in device "Settings" .
- No video (screen without red dot):
 - a. The microSD card is not formatted or corrupted.
 - b. The microSD card is not inserted in place.
- The image display is hazy or blurry: Check if the lens is dirty.

12. Technical Support Contact Info

For any questions about **MiNy360**, please contact your retailer or RYDEEN Technical Support:

- Phone: **1-310-787-7880** Fax: **1-310-787-7881**
- Email: tech1@rydeenmobile.com
- Web: <https://rydeenmobile.com/contact-support/>

13. One Year Limited Warranty

RYDEEN MOBILE (a manufacturer of "RYDEEN" products) warrants product (MiNy360) only to the original purchaser as described following:

Warranty Period

Rydeen warrants this product for a period of one (1) year from the original purchase date.

Warranty Coverage

This warranty covers all defects in material and workmanship except as specified below.

1. Any products distributed outside of the USA by Rydeen North America, Inc. (Rydeen) or which is not purchased in the USA or Canada unless the product is purchased through the USA Military Exchange Service.
2. Any product(s) which are purchased from an unauthorized retailer (in store or online).
3. Any products in which the serial number label or the model number label are removed, torn, modified or replicated.
4. Any damage defects or malfunctions resulting from any of following:
 - a) When defect occurs during shipment of product (freight carrier's responsibility).
 - b) Installation or removal of product.
 - c) Accidents, act of nature, misuse, abuse, neglect, unauthorized product modification or failure to follow product owner's manual instructions.
 - d) Any repair or attempt to repair without RYDEEN authorization.
 - e) Any other cause which is not related to product defect.
 - f) Any cosmetic damages due to normal wear and tear.
 - g) Any consumable items (such as fuse or batteries).

If any problems develop with your Rydeen products during or after the Limited Warranty Period, or if you have any questions regarding the operation or installation of the product, you should contact your Rydeen retailer. If the problem or your question is not handled to your satisfaction, please contact Rydeen Customer Service Department at 1-310-787-7880 on Monday-Friday between 8:00 AM to 5:00 PM Pacific Standard Time or visit www.Rydeenmobile.com.

14. To Obtain Warranty Service

If warranty service is required for your Rydeen product:

1. Please call Rydeen Customer Service Department at 1-310-787-7880, Monday-Friday between 8:00 AM to 5:00 PM Pacific Standard time and obtain a Return Authorization Number ("RA") Number.
2. Please pay for any shipping charge to Rydeen Customer Service Department. Rydeen will pay the return shipping charge, if the repair or service was performed during the warranty period. Rydeen will ship freight collect (recipient is responsible for shipping charge) if Rydeen determine the service was performed outside of warranty period or exclusions described above. Rydeen will not accept warranty service requests from outside of the U.S.A. even if product was purchased in the USA.
3. Please include a copy of your original purchase receipt including Rydeen product model number, purchase date, retailer name/address and a RA Number whenever your product is sent for warranty service.

4. Rydeen will pay for all labor and material expenses for covered product during warranty period.
5. Shipping address for Rydeen Customer Service Department is following:
Rydeen North America, Inc. (a manufacturer of Rydeen products), 2701 Plaza Del Amo, Unit 705, Torrance, California 90503, USA.

15. FCC Compliance Statement

This device complies with Part 15 of the FCC interference limits for Class B digital devices for home or office use. These limits are designed to provide more reasonable protection against harmful interference in a residential installation and are more stringent than "outdoor" requirements.

Operation of this device is subject to the following conditions:

1. This device may not cause harmful interference, and
2. This device must accept any interference received, including interference that may cause undesired operation.

16. Copyright

1. Intellectual Property Rights of Software are proprietary to RYDEEN North America, Inc. or its suppliers and are subject to copyright and other intellectual property laws. Client's only rights with respect to any RYDEEN North America, Inc. software included with the products shall be provided, under the terms of RYDEEN North America, Inc. software license. The title to all RYDEEN North America, Inc. Software remains with RYDEEN North America, Inc. Client agrees that RYDEEN North America, Inc. retains ownership of all rights, title and interest in all intellectual property, works of authorship, trade secrets and the like in all aspects of the Product(s). Client and its affiliates and subcontractors agree not to reverse engineer any aspect of the Software and/or Products supplied under this agreement and further agree to pay assessed damages should such action take place.
2. Copyright and Copies. The Software (including any copy thereof) is owned by RYDEEN North America, Inc. or its suppliers and is protected by United States, Canadian, European, Brazilian and Australian copyright and patent laws and international treaty provisions. The Software copy is licensed to you the client, not sold to you, and you (the client) are not an owner of any copy thereof. You may make one copy of the software for backup or archival purposes. You may not otherwise copy the software, except as authorized by applicable law, nor the written materials accompanying the Software. RYDEEN North America, Inc. hereby reserves all rights not explicitly granted in this license agreement.
Software Copyright © 2026, RYDEEN North America, Inc.

17. Disclaimer

The information in this user's manual is for general guidance. The images in the manual may be similar to the images shown in the actual product, but they do not exactly match. Depending on the optional package, some functions described in the manual may not be available or the functions described may be restricted.

RYDEEN[®]

rydeenmobile.com

Rydeen North America, Inc.

2701 Plaza Del Amo, Suite 705, Torrance, California 90503 USA

Phone: 1-310-787-7880 Fax: 1-310-787-7881

Copyright © 2026 Rydeen North America, Inc. All Rights Reserved.

RYDEEN[®] is a registered trademark of Rydeen North America, Inc.

These materials are protected by copyright law and international treaties. Any unauthorized use, reproduction or distribution of these materials, or any portion herein, will result in severe civil and criminal penalties and fines. Violators will be prosecuted to the fullest extent of the law.