

RYDEEN[®]



PV8-AX



PV8-BX

RYDEEN
AHD
ECO SYSTEM

Owner's Manual

PV8-AX / PV8-BX

**8.2-inch HD Screen Digital
Rearview Mirror**

Contents

| | |
|---|-----------|
| 1. Welcome Statement & Warnings..... | 2 |
| PRECAUTIONS & WARNINGS | 2 |
| 2. What's in the Box | 4 |
| OPTIONAL ACCESSORIES..... | 5 |
| 3. Product Overview | 6 |
| Wiring Diagram | 7 |
| 4. Installation | 8 |
| Mirror Replacement Method..... | 8 |
| 5. User Interfaces | 11 |
| Brightness Setting Icon | 11 |
| General Settings Icon | 12 |
| Parking Line Display | 12 |
| Parking Line Selection | 12 |
| Rear Mirror Image..... | 13 |
| Front Mirror Image..... | 13 |
| Camera Input Selection | 13 |
| Language..... | 13 |
| Screensaver | 14 |
| Reverse Trigger Enable | 14 |
| Sound | 14 |
| Format microSD..... | 14 |
| Factory Reset | 15 |
| Firmware Version | 15 |
| 6. Specifications | 16 |
| 7. Maintaining Your Mirror Display | 17 |
| 8. Technical Support Contact Info..... | 17 |
| 9. One Year Limited Warranty..... | 17 |
| 10. To Obtain Warranty Service | 18 |
| 11. FCC Compliance Statement | 19 |
| 12. Copyright..... | 19 |
| 13. Disclaimer..... | 20 |
| 14. Troubleshooting..... | 20 |

1. Welcome Statement & Warnings

Congratulations and thank you for purchasing RYDEEN PV8-AX / PV8-BX, our 2-channel input rearview mirror with high resolution display. We hope you'll enjoy using this exciting product and trust that it will make your driving experience more comfortable and hassle-free. The PV8-AX / PV8-BX is an 8.2-inch high-definition touch screen rearview mirror equipped with a high-definition digital camera that can be used together with a rear or front facing camera. When the use of the display is no longer needed, the display can manually be turned off to serve as a rearview mirror.

Please read this Owner's Manual carefully. After you have finished reading the instructions, keep this document in a safe place for future reference. If you have any further questions about your PV8-AX / PV8-BX operation, feel free to call RYDEEN, Toll Free at 1-310-787-7880 (within USA only) for product support, or visit our website: www.rydeenmobile.com

PRECAUTIONS & WARNINGS

IMPORTANT INFORMATION

PLEASE READ THIS MANUAL CAREFULLY BEFORE USING THE PRODUCT

The Rydeen PV8-AX / PV8-BX aims to provide you with a safer, more comfortable and convenient driving experience. Therefore, we recommend that you read and follow all the information and instructions in this user manual to make your PV8-AX/ PV8-BX achieve the best performance and satisfaction.

- Your PV8-AX / PV8-BX **IS NOT** a substitute for personal judgment. The field of view of the backup camera of this product is limited. Some objects, roads and other vehicles may not be visible. **ALWAYS LOOK AHEAD, LOOK AROUND, KEEP A SAFE DISTANCE FROM OTHER VEHICLES WHEN DRIVING AND PARKING, DO NOT JUST USE A REARVIEW MIRROR. DO NOT DEPEND SOLELY ON THE PRODUCT FOR COMPLETE FIELD OF VIEW.**
- Objects displayed in the mirror may be closer than they appear. When changing or merging into a lane, please check your sideview mirrors and check your surroundings of the vehicle to avoid injury, death or vehicle damage that may be caused by this operation.

- **DO NOT OPERATE THIS PRODUCT or TOUCHSCREEN WHILE THE VEHICLE IS IN MOTION**, as those actions may affect safe driving. If you need to operate, please park the vehicle in a safe area before performing elated operations.
- **SEVERE INJURY RISK- DO NOT** mount your PV8-AX / PV8-BX on the surface or in the deployment field of your vehicle's driver and passenger airbag units.
- **SEVERE INJURY RISK- SECURE THE MOUNTING** of your PV8-AX / PV8-BX firmly, to avoid the risk of injury to the passengers in the event of a vehicle accident or collision.
- Position the unit in a location that does not obstruct the driver's view of the road, instruments or vehicle controls.
- Make sure that the PV8-AX / PV8-BX device and the provided bracket are properly attached to the vehicle's windshield.
- **DO NOT** attempt to modify or disassemble the PV8-AX / PV8-BX unit. Personal injury or damage could result. If a problem occurs, stop using the system immediately and contact RYDEEN. Changes or modifications to the PV8-AX / PV8-BX will void the warranty and its compliance with FCC rules.
- If you notice any of the following: (Unidentified liquid on the unit; smoke rising out of the unit; unusual odor emanating from the unit) – STOP USING THE UNIT IMMEDIATELY. Contact the nearest RYDEEN retailer or call RYDEEN Customer Service for assistance Toll Free @ 1-310-787-7880.
- **DO NOT** mount your PV8-AX / PV8-BX on any non-automotive form of transportation(motorcycles, bikes, ATV's, watercraft).
- The appearance of the product shown in this manual may be different from the actual product, please refer to the actual product.
- The picture examples used in this manual may be different compared to the actual vehicle, please use as reference.
- The picture examples used in this manual may be different compared to the actual user interface of this device, please use as reference.



WARNINGS



- **DO NOT DROP ANY COMPONENTS OF THIS PRODUCT.** Excessive shock due to dropping any components in the system or subjecting it to excessive shock and vibrations may cause malfunction and is not covered by warranty.
- **DO NOT** use any sharp object to operate your unit's touch-screen display.
- Excessive force could damage the LCD display.
- **THE PV8-AX / PV8-BX UNIT IS NOT WATERPROOF.** Avoid exposing it to rain or other forms of excessive moisture. **Only the rear camera is waterproof.**
- **Water damage is not covered under the warranty.**
- **THE FOLLOWING INSTRUCTIONS ARE RECOMMENDED FOR AUTHORIZED RYDEEN MOBILE INSTALLERS.**

2. What's in the Box

When opening the packaging box of this product, please make sure that all product accessories are complete.

Standard Package



PV8-AX / PV8-BX Unit

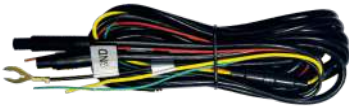

Power Wire Harness*1



CM-AHD5 camera*1



VSM-AV*1



27ft AHD Camera Extension Cable*1



D-Tab*1



L-shaped Tool*1

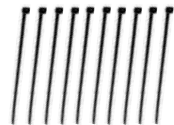

Strap*10

OPTIONAL ACCESSORIES



If you want to purchase the optional accessories, please contact your retailer or contact RYDEEN, Toll Free at 1-310-787-7880 for product support, or visit our website: <https://rydeenmobile.com/>

RYDEEN OED-01(SOLD SEPARATELY)



AHD Front Facing Dash Cam

RYDEEN CM-D700 AHD (AHD Video Switcher, SOLD SEPARATELY)

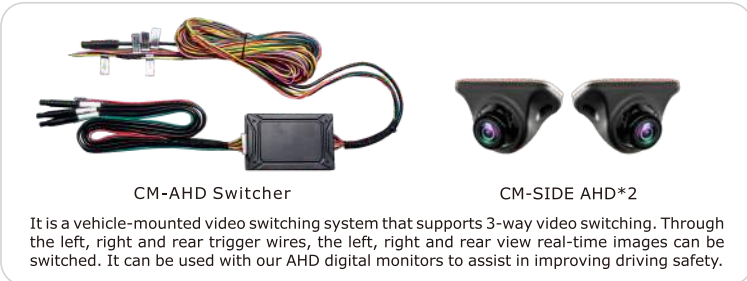

CM-AHD Switcher

CM-SIDE AHD*2

It is a vehicle-mounted video switching system that supports 3-way video switching. Through the left, right and rear trigger wires, the left, right and rear view real-time images can be switched. It can be used with our AHD digital monitors to assist in improving driving safety.

OPTIONAL ACCESSORIES USAGE SCENARIOS

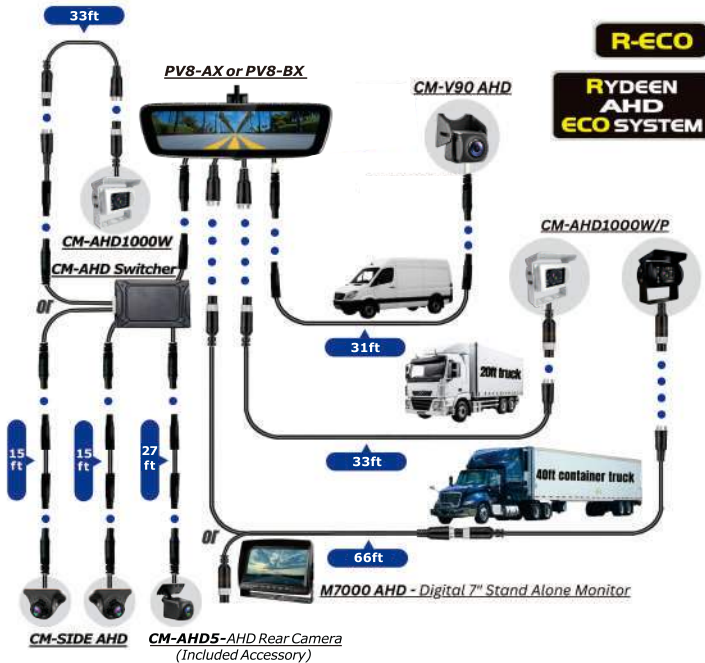

3. Product Overview

PV8-AX / PV8-BX Unit

FRONT



BACK



BOTTOM



| No. | Item | Description |
|-----|-------------------|---|
| 1 | Touch screen | Set basic functions by touching the screen. |
| 2 | Power button | Short press to turn On/Off the LCD Monitor. Long press to Power On/Off. |
| 3 | MicroSD card slot | Use microSD card slot to update the PV8-AX / PV8-BX. |

| | | |
|---|--------------|---|
| 4 | Photo sensor | The photo sensor is used to adjust the screen brightness automatically. |
| 5 | Reset hole | Press and hold within reset hole to restart the PV8-AX / PV8-BX. |

Wiring Diagram

Yellow - Constant +12V source.

Red - Ignition controlled ACC source.

Black - Ground (-) Polarity (Connect to car chassis or ground point).

Green - Reverse Trigger (+) (Connect to reverse wire).

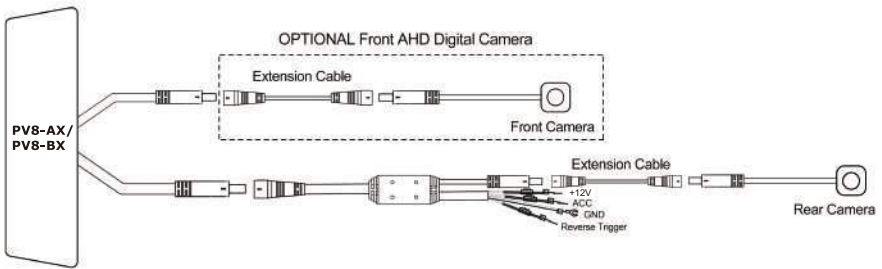

OPTIONAL CM-D700 AHD (AHD VIDEO SWITCHER)

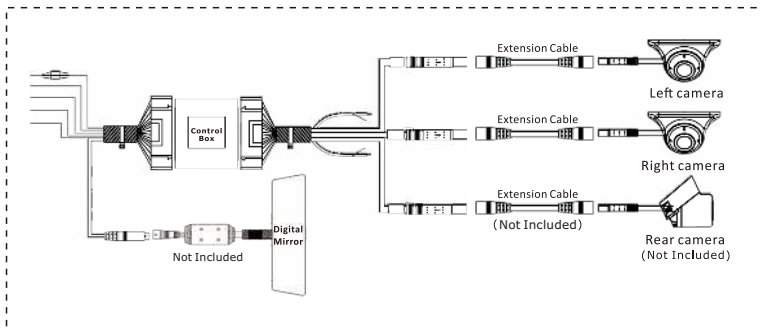

4. Installation



- **THE FOLLOWING INSTRUCTIONS ARE INTENDED TO GIVE YOU A BRIEF GUIDANCE FOR INSTALLATION.**
- **Dropping your PV8-AX / PV8-BX unit or subjecting it to excessive shock and vibrations as this may cause it to malfunction and is not covered by warranty.**
- **The PV8-AX / PV8-BX unit IS NOT WATERPROOF. Avoid exposing it to rain or other forms of excessive moisture. Water damage is not covered under the warranty. Only the rear camera is waterproof.**
- **Most vehicles have the mirror mounted directly onto the glass, therefore improper tools or techniques used in the installation could result in a damaged or broken windshield. Rydeen is not responsible for damages to windshield caused by installation processes.**

Mirror Replacement Method

Step 1

Remove the existing mirror and unplug the connector, if one exists. (Note: All vehicles use different mounting solutions. If necessary, consult your local automotive dealer or installation professional for specific instructions.)



Note: If your vehicle uses a universal D-Tab mount, do not remove the D-Tab and use the VSM-AV mount provided.

- 1) Attach VSM-AV mount onto the PV8-AX / PV8-BX Back Plate using provided screws.
- 2) Reattach the PV8-AX / PV8-BX mirror by sliding the VSM-AV mount onto the factory windshield tab.
- 3) Adjust to the suitable angle to the mirror, then proceed to **Step 2**.

Step 2

Connect each unit according to the wiring diagram (page 7).

1) Route the wires along the interior trim panel and go down the A-pillar, use the pry tool (not included) to tuck the wires within the panels. Make sure your ACC, GND, +12V and Reverse Trigger are connected.

2) Follow the wiring diagram, install the backup camera.

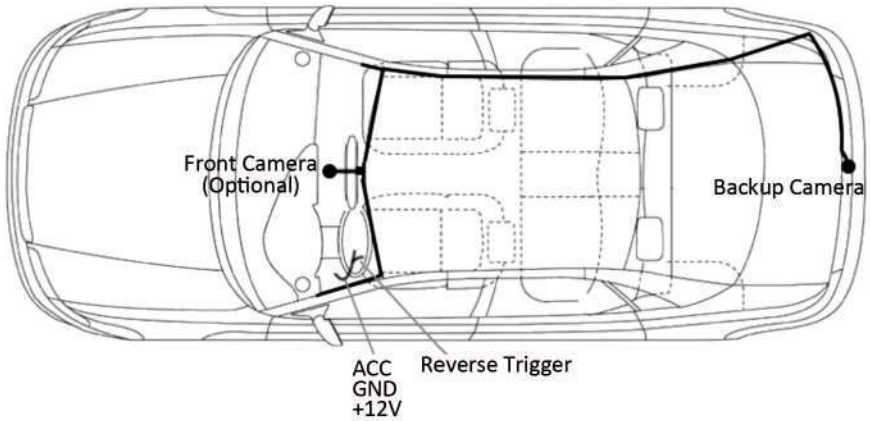
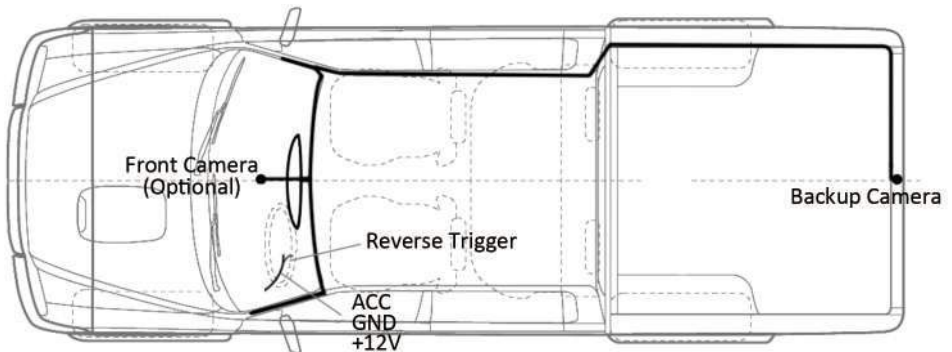
For Cars**For Trucks**

Inside View

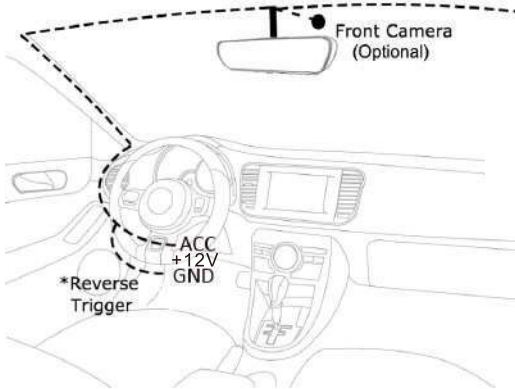

* Reverse Trigger: Only works when backup camera connected.

Camera Installation Position Option Diagram

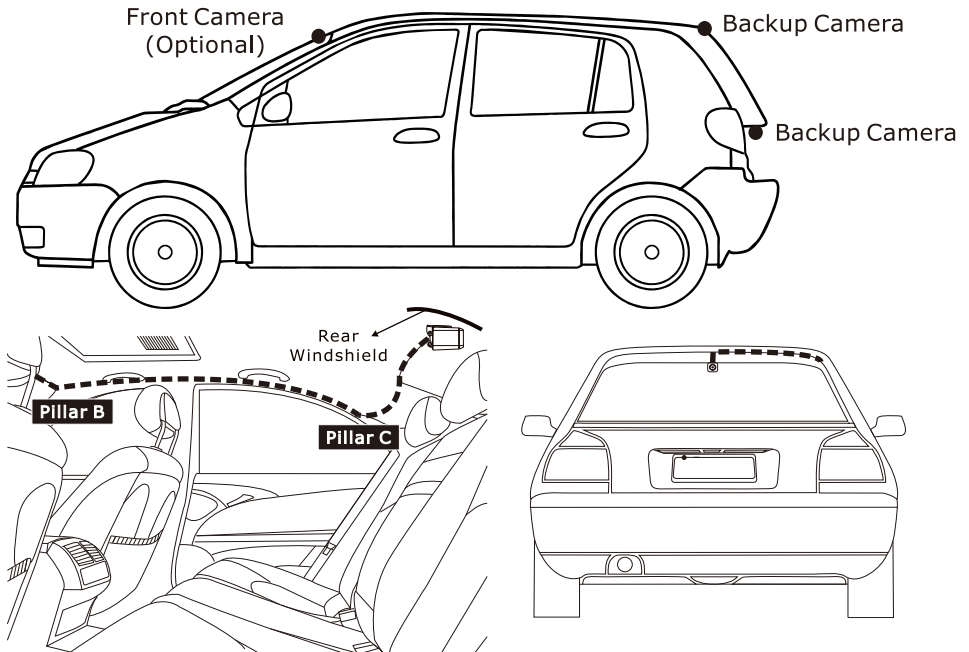

Backup Camera: The backup camera should be mounted above the license plate, recessed 1/2 Inch, in order to avoid rain or precipitation to run on the surface of camera lens.

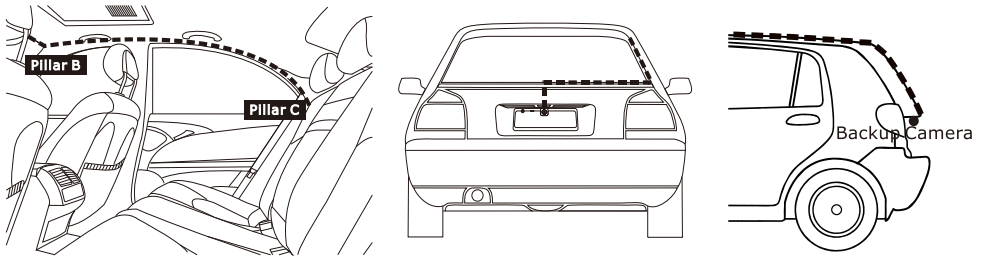

Yellow - Constant 12V+ source.

Red - Ignition controlled ACC source.

Black - Ground (-) Polarity (Connect to car chassis or ground point).

Green - Reverse Trigger (+) (Connect to reverse wire).

Step 3

Turn the vehicle on and verify that all the functions are working properly.

5. User Interfaces

Start-up Screen





Power down Screen



Main UI



Brightness Setting Icon

You can press this  icon to turn On/Off the auto dimming function of LCD screen, while turning off auto dimming, you can click the brightness bar to manually set the screen brightness and will shows  icon. The PV8-AX / PV8-BX mirror will retain the last brightness settings.



General Settings Icon

Select this icon to enter the general settings menu.

Page 1

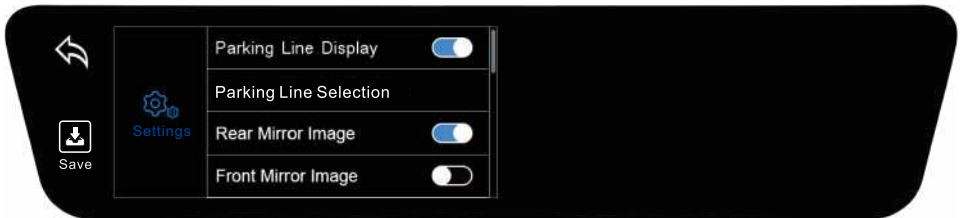

Parking Line Display-----Turn on/off Parking Line, default setting is on.

Parking Line Selection ----- Select the parking line style for display. Three preset modes are available: High, Mid, and Low. The parking lines can also be manually adjusted using the on-screen controls (Up, Down, Left, and Right). Adjusted settings can be saved and will be retained for future use.

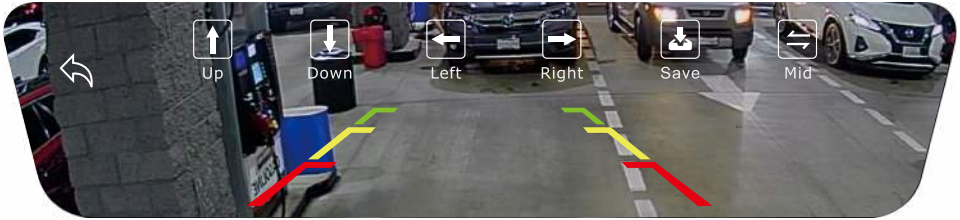

Rear Mirror Image-----Control mirrored image displayed on the rear camera.

Front Mirror Image-----Control mirrored image displayed on the front camera.

Page 2



Camera Input Selection-----Select the camera input for start up and the main interface display. Rear camera is the default. If the selected camera is not connected, the mirror will default to the camera connected. When selecting "Off", the screen will only display when reverse trigger is engaged (This feature only works when "Reverse Trigger Enable" is selected as "on").

Note: After selecting "Off", if the user turns on the screen by touching it or manually pressing the power button, the screen will turn off again after remaining on for 30 seconds without any further interaction. If the screen is awakened by triggering the reverse function, it will turn off again once the reverse cable is disconnected.

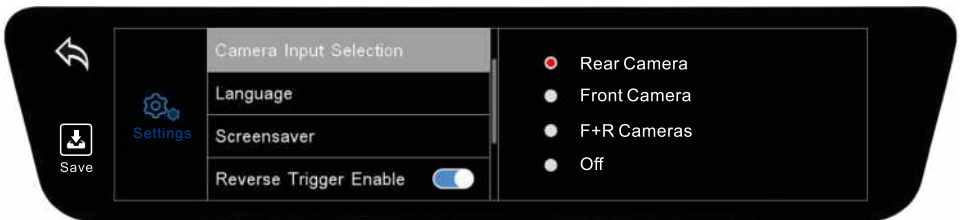

Language-----Select the system language, there are four languages(English, French, Spanish, and Japanese)

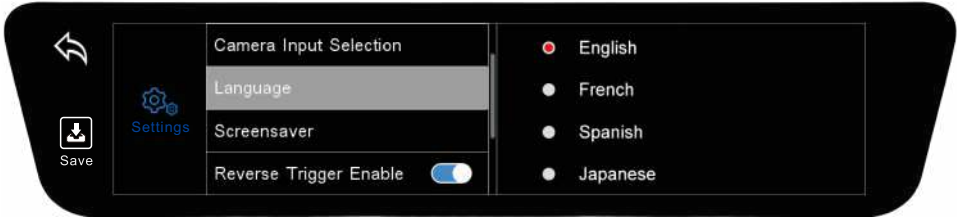

Screensaver-----Mirror display will turn off after selected time has been reached with no usage. Selecting "Off" will keep display on during vehicle operation.



Reverse Trigger Enable-----Enable or disable the reverse trigger function.

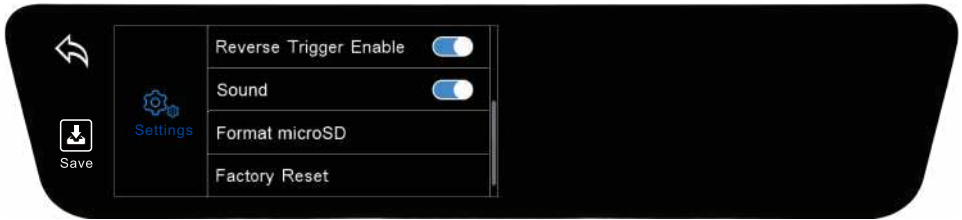

Sound-----Turn on/off the key sounds.

Format microSD----- Select "Format microSD" to delete all files in the microSD card.

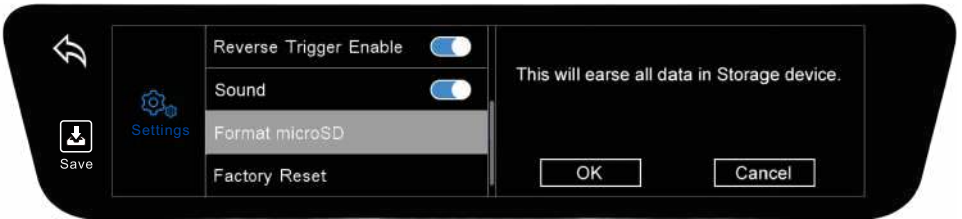

Factory Reset-----Select this function to reset all settings back to default.

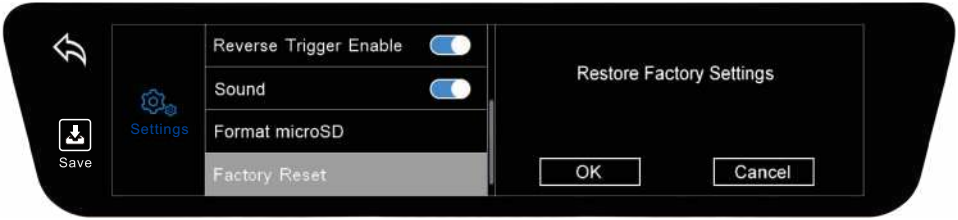

Page 4

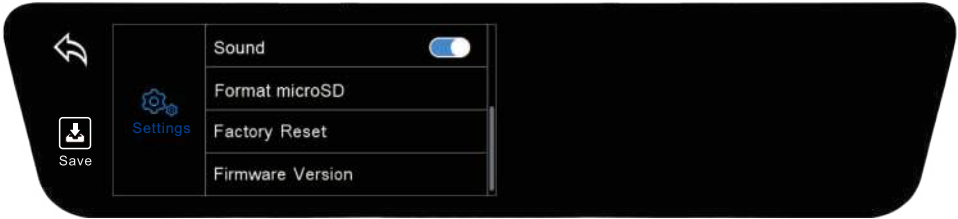

Firmware Version-----Shows current software version installed in your device.

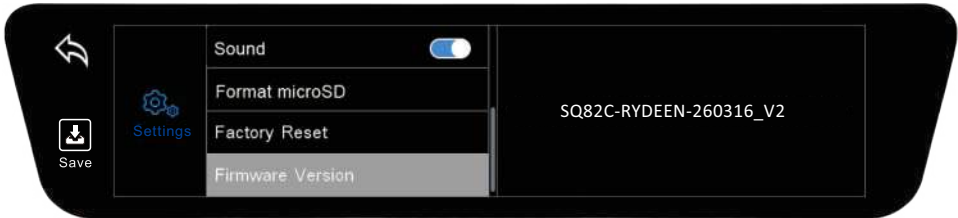

Note: After adjusting the settings, tap "Save" to apply and store your changes.

6. Specifications

| Basic Parameters | |
|-----------------------------|------------------------------------|
| Operation System | RTOS |
| Video Input (backup camera) | AHD |
| System Language | English, French, Spanish, Japanese |
| Screen Dimensions | 8.2 inches |
| Touch Screen Type | Capacitive |
| Screen Resolution | 1280*288 |
| Audio Line-Out | Built-in 1W, 8Q |
| Power Supply Voltage | DC 12V |
| Power Supply Current | 1.5A |
| Operational Temperature | -20°C~ +70°C |
| Storage Temperature | -30°C~ +80°C |
| Peak Screen Brightness | 2200cd/m ² |
| Backup Camera Parameters | |
| Minimum illuminance | 0.1 lux |
| Frame Rate | 30fps |
| Water Proof | IP67 |
| Resolution | 1920*1080 |
| Viewing Angle | H 108°±5°, V 60°±5° |

7. Maintaining Your Mirror Display

Cleaning the Unit:

1. Use a soft, dry cloth to wipe away dirt.
2. If the dirt cannot be wiped away, dampen the cloth with water to clean the unit.
NOTE: Do not wash the unit with running water as this unit is not water proof.
3. Use a dry cloth to wipe away residual moisture when done.
NOTE: Do not use solvent, car cleaner or organic cleaners to clean the unit. These substances may damage the Mirror Display.

Cleaning the LCD Display:

1. Turn off the system while cleaning the display to prevent static electricity.
2. Use a soft, dry cloth to wipe away dirt.
3. The display surface is easily scratched. Do not use hard objects to scrape or come in contact with the display surface.

8. Technical Support Contact Info

For any questions about **PV8-AX / PV8-BX**, please contact your retailer or RYDEEN Technical Support:

- Phone: **1-310-787-7880** Fax: **1-310-787-7881**
- Email: tech1@rydeenmobile.com
- Web: <https://rydeenmobile.com/contact-support/>

9. One Year Limited Warranty

RYDEEN MOBILE (a manufacturer of "RYDEEN" products) warrants product (PV8-AX / PV8-BX) only to the original purchaser as described following:

Warranty Period

Rydeen warrants this product for a period of one (1) year from the original purchase date.

Warranty Coverage

This warranty covers all defects in material and workmanship except as specified below.

1. Any products distributed outside of the USA by Rydeen North America, Inc. (Rydeen) or which is not purchased in the USA or Canada unless the product is purchased through the USA Military Exchange Service.
2. Any product(s) which are purchased from an unauthorized retailer (in store or online).
3. Any products in which the serial number label or the model number label are removed, torn, modified or replicated.
4. Any damage defects or malfunctions resulting from any of following:
 - a) When defect occurs during shipment of product (freight carrier's responsibility).
 - b) Installation or removal of product.
 - c) Accidents, act of nature, misuse, abuse, neglect, unauthorized product modification or failure to follow product owner's manual instructions.
 - d) Any repair or attempt to repair without RYDEEN authorization.
 - e) Any other cause which is not related to product defect.
 - f) Any cosmetic damages due to normal wear and tear.
 - g) Any consumable items (such as fuse or batteries).

If any problems develop with your Rydeen products during or after the Limited Warranty Period, or if you have any questions regarding the operation or installation of the product, you should contact your Rydeen retailer. If the problem or your question is not handled to your satisfaction, please contact Rydeen Customer Service Department at 1-310-787-7880 on Monday -Friday between 8:00 AM to 5:00 PM Pacific Standard Time or visit www.rydeenmobile.com.

Note: If serial number label is removed no warranty.

10. To Obtain Warranty Service

If warranty service is required for your Rydeen product:

1. Please call Rydeen Customer Service Department at 1-310-787-7880, Monday-Friday between 8:00 AM to 5:00 PM Pacific Standard time and obtain a Return Authorization Number ("RA") Number.
2. Please pay for any shipping charge to Rydeen Customer Service Department. Rydeen will pay the return shipping charge. If the repair or service was performed during the warranty period. Rydeen will ship freight collect (recipient is responsible for shipping charge) if Rydeen determine the service was performed outside of warranty period or exclusions described above. Rydeen will not accept warranty service requests from outside of the U.S.A. even if product was purchased in the USA.
3. Please include a copy of your original purchase receipt including Rydeen product model number, purchase date, retailer name/address and a RA Number whenever your product is sent for warranty service.

4. Rydeen will pay for all labor and material expenses for covered product during warranty period.
5. Shipping address for Rydeen Customer Service Department is following:
Rydeen North America, Inc. (a manufacturer of Rydeen products), 2701 Plaza Del Amo, Unit 705, Torrance, California 90503, USA.

11. FCC Compliance Statement

This device complies with Part 15 of the FCC interference limits for Class B digital devices for home or office use. These limits are designed to provide more reasonable protection against harmful interference in a residential installation and are more stringent than "outdoor" requirements.

Operation of this device is subject to the following conditions:

1. This device may not cause harmful interference, and
2. This device must accept any interference received, including interference that may cause undesired operation.

12. Copyright

1. Intellectual Property Rights of Software are proprietary to RYDEEN North America, Inc. or its suppliers and are subject to copyright and other intellectual property laws. Client's only rights with respect to any RYDEEN North America, Inc. software included with the products shall be provided, under the terms of RYDEEN North America, Inc. software license. The title to all RYDEEN North America, Inc. Software remains with RYDEEN North America, Inc. Client agrees that RYDEEN North America, Inc. retains ownership of all rights, title and interest in all intellectual property, works of authorship, trade secrets and the like in all aspects of the Product(s). Client and its affiliates and subcontractors agree not to reverse engineer any aspect of the Software and/or Products supplied under this agreement and further agree to pay assessed damages should such action take place.
2. Copyright and Copies. The Software (including any copy thereof) is owned by RYDEEN North America, Inc. or its suppliers and is protected by United States, Canadian, European, Brazilian and Australian copyright and patent laws and international treaty provisions. The Software copy is licensed to you the client, not sold to you, and you (the client) are not an owner of any copy thereof. You may make one copy of the software for backup or archival purposes. You may not otherwise copy the software, except as authorized by applicable law, nor the written materials accompanying the Software. RYDEEN North America, Inc. hereby reserves all rights not explicitly granted in this license agreement.
Software Copyright © 2026, RYDEEN North America, Inc.

13. Disclaimer

The information in this user's manual is for general guidance. The images in the manual may be similar to the images shown in the actual product, but they do not exactly match. Depending on the optional package, some functions described in the manual may not be available or the functions described may be restricted.

14. Troubleshooting

Solutions for Common Problems

1. NO display: Check to ensure the screen cable is properly connected and terminal connection is not loose.
2. Rydeen logo stuck on screen start-up. Please insert a small pin into the reset hole and restart.

RYDEEN[®]

rydeenmobile.com

Rydeen North America, Inc.

2701 Plaza Del Amo, Suite 705, Torrance, California 90503 USA

Phone: 1-310-787-7880 Fax: 1-310-787-7881

Copyright © 2026 Rydeen North America, Inc. All Rights Reserved.

RYDEEN[®] is a registered trademark of Rydeen North America, Inc.

These materials are protected by copyright law and international treaties. Any unauthorized use, reproduction or distribution of these materials, or any portion herein, will result in severe civil and criminal penalties, and fines. Violators will be prosecuted to the fullest extent of the law.